



Grammar **EXPRESS** and Composition

Author by :
Aayush Sharma
Ma (English) M.E.D., Ph.D

Key 1 to 5



Test Paper
Generator



E-Teacher
Manual



Smart
Application



Web
Support

C. Fill in the blanks :

- | | | | |
|-------------|-------|--------------|------------|
| 1. G is for | Girl | 6. T is for | Tiger |
| 2. J is for | Joker | 7. U is for | Umbrella |
| 3. K is for | Kite | 8. V is for | Van |
| 4. O is for | Owl | 9. X is for | X-mas tree |
| 5. S is for | Ship | 10. Z is for | Zoo |

D. Write Small Letters for the following Capital Letters :

| | | | | | |
|---|-----------|---|-----------|---|-----------|
| A | a, | B | b, | C | c, |
| D | d, | E | e, | F | f, |
| G | g, | H | h, | I | i, |
| J | j, | K | k, | L | l, |
| M | m, | N | n, | O | o, |
| P | p, | Q | q, | R | r, |
| S | s, | T | t, | U | u, |
| V | v, | W | w, | X | x, |
| Y | y, | Z | z. | | |

E. Write Capital Letters for the following Small Letters :

| | | | | | |
|---|-----------|---|-----------|---|-----------|
| b | B, | d | D, | f | F, |
| h | H, | j | J, | l | L, |
| n | N, | p | P, | r | R, |
| t | T, | v | V, | x | X, |
| a | A, | c | C, | e | E, |

2

Words and Sentence

A. Use capital letter and full stop in each of the following sentences:

1. we are going to delhi

Ans. We are going to Delhi.

2. cat killed a rat

Ans. A cat killed a rat.

3. birds have wings

Ans. Birds have wings.

4. the man is wise

Ans. The man is wise.

5. i drink milk daily

Ans. I drink milk daily.

6. the food is hot

Ans. The food is hot.

B. Make sentences from the groups of words given below.

1. dancing the is girl

Ans. The girl is dancing.

2. naughty is very Sagar

Ans. Sagar is very naughty.

3. grass the is green

Ans. The grass is green.

4. Meerut live I in

Ans. I live in Meerut.

5. Siya reading a is book

Ans. Siya is reading a book.

3

Nouns

A. Tick (✓) the right option:

1. Which of the following, is the name of a person?

Ans. (c) Doctor

2. Which of the following, is the name of a animal?

Ans. (a) Monkey

3. Which of the following is the name of a place?

Ans. (a) Station

4. Which of the following is the name of thing?

Ans. (b) Clock

C. Match the following:

'A'

1. Teacher

2. Cow

3. Parrot

4. Book

5. Temple

'B'

(d) Person

(a) Animal

(e) Bird

(c) Thing

(b) Place

D. Answer the following questions:

1. What is called Noun?

Ans. A noun is the name of a person, place, animal, or thing.

2. Give five examples of Noun.

Ans. Boy, School, Dog, Book, Temple

4

Pronouns

A. Tick (✓) the right option:

1. _____ are good friends.

Ans. (c) They

2. Smita is my sister. _____ is good in study.

Ans. (b) She

3. _____ is a good player.

Ans. (a) He

B. Fill in the blanks with the correct Pronoun given in the brackets:

1. **She** is my mother.
2. **It** is a new car.
3. **They** are soldiers of India.
4. Cat loves milk. **It** drinks milk daily.

C. Circle the Pronouns in the given sentences:

1. Priya is my best friend. (She) likes reading books.
2. Aditya cried because (he) hurt (himself).
3. Chinki reads a book. (It) has good pictures in (it).

D. Answer the following questions:

1. What is Pronoun?

Ans. A pronoun is a word that is used in place of a noun.

2. Write the words which are used as Pronouns.

Ans. I, You, He, She, It, We, They, Me, Us, Them.

5

Gender

A. Tick (✓) the right option:

1. The gender which refers to males is called :

Ans. (a) Masculine

2. The word 'queen' denotes :

Ans. (b) Feminine

3. The opposite gender of 'niece' is:

Ans. (b) nephew

B. See the pictures and write male or female :



Female



Male

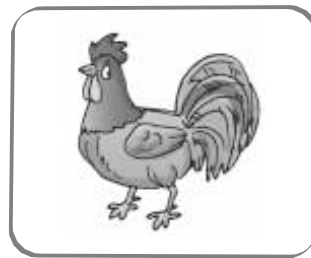

Male



Female

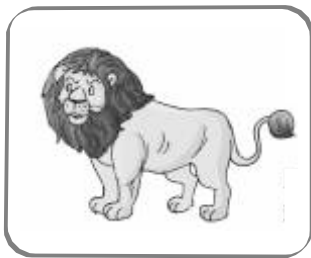

Male

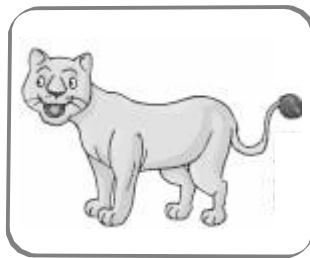

Female



Male



Female

C. Match the following:

'A'

1. hen
2. actor
3. king
4. headmistress
5. nephew
6. vixen

'B'

- (d) cock
- (f) actress
- (a) queen
- (c) headmaster
- (b) niece
- (e) fox

D. Change the gender of the following nouns :

- | | | |
|------------------------|--------------------------|----------------------|
| 1. sir madam | 2. mare horse | 3. aunt uncle |
| 4. husband wife | 5. brother sister | 6. cow bull |
| 7. daughter son | 8. dog bitch | 9. man woman |

E. Rewrite these sentences changing the noun in colour to their opposite gender :

1. My father has gone out to work.

Ans. My mother has gone out to work.

2. My sister is a teacher.

Ans. My brother is a teacher.

3. He is a boy.

Ans. She is a girl.

4. The lion is the king of the jungle.

Ans. The lioness is the queen of the jungle.

5. Mr. Jain has four daughters.

Ans. Mr. Jain has four sons.

6

Adjectives : Describing Words

A. Tick (✓) the right option:

1. All describing word are:

Ans. (b) Adjectives

2. Which of the following is an adjective?

Ans. (b) Big

3. Adjectives are almost put before the _____.

Ans. (b) Nouns

B. Fill in the blanks with the Adjectives:

1. The Sun is very **hot**.

2. My sister is **intelligent** in Mathematics.

3. My jacket is **black**.

4. This man wears **clean** clothes.

C. Match the Adjectives with the Nouns and write in the given space:

Adjectives

Nouns

Answer

Big

car

Big car

Hot

tea

Hot tea

High

hill

High hill

| | | |
|-------|-------|--------------------|
| Fat | man | Fat man |
| Clean | cloth | Clean cloth |

D. Pick out the Adjective in the following sentences :

Sentences

1. Raj is clever and intelligent boy.
2. Delhi is a large, busy city.
3. Mr. Rohan is a kind man.
4. Goa is a beautiful place.
5. The grapes are very sweet.

Adjective

- clever, intelligent**
large, busy
kind
beautiful
sweet

E. Answer the following questions :

1. What are Adjectives?

Ans. Adjectives are describing words. They describe a noun or pronoun.

2. Give some examples of Adjectives.

Ans. big, small, tall, fat, red, beautiful, clean.

7 Comparison

A. Write the degree of comparison :

| | | |
|----------|---------------|----------------|
| 1. Dry | Drier | Driest |
| 2. Hot | Hotter | Hottest |
| 3. Big | Bigger | Biggest |
| 4. Slow | Slower | Slowest |
| 5. Fast | Faster | Fastest |
| 6. Large | Larger | Largest |
| 7. Brave | Braver | Bravest |

| | | |
|----------|----------------|-----------------|
| 8. Funny | Funnier | Funniest |
| 9. Cold | Colder | Coldest |
| 10. Much | More | Most |

B. Fill in the blanks with the appropriate words :

1. A good book is better than a newspaper.
2. Juhi is taller than her sister.
3. Raj is stronger than Rohan.
4. Mangoes are sweeter than grapes.
5. Watches are costlier than shoes.
6. There is less water in the tank than in the sea.

8

Singular and Plural

A. Tick (✓) the right option:

1. Which is the Plural of tree?

Ans. (c) Trees

2. Which is the Singular of car?

Ans. (b) Cars

3. Which is the Plural of aeroplane?

Ans. (a) Aeroplanes

B. Match the following:

'A'

'B'

- | | |
|-------------|---------------|
| 1. Elephant | (d) Elephants |
| 2. Mountain | (e) Mountains |
| 3. Table | (c) Tables |

4. Monkey (b) Monkeys
5. Cow (a) Cows

C. Change the Singular into Plural by adding -s at the end of each word :

| | | | |
|----------|------------------|---------|-----------------|
| Bat | Bats | Soldier | Soldiers |
| Computer | Computers | Camera | Cameras |

D. Answer the following questions :

1. What is called Singular?

Ans. A singular word is a word that names one person, place, animal, or thing.

2. What do you know about Plural?

Ans. A plural word is a word that names more than one person, place, animal, or thing.



Use of 'Is', 'Am' and 'Are'

A. Tick (✓) the right option :

1. 'Is' is used with :

Ans. (a) She

2. 'Are' is used with :

Ans. (c) They

3. 'Am' is used with :

Ans. (a) I

B. Fill in the blanks with is, am and are :

1. Apples are sweet fruits.

2. You are a boy.

3. She is a doctor.

4. We **are** eating.
5. What **is** your father?
6. It **is** an ox.
7. I **am** a good student.
8. They **are** my friends.
9. The train **is** late.

C. Answer the following questions :

1. Where do we use 'Is'?

Ans. We use 'is' with singular subjects (he, she, it).

2. Where do we use 'Are'?

Ans. We use 'are' with plural subjects (we, they, you).

3. Where do we use 'Am'?

Ans. We use 'am' only with 'I'.

10

Use of 'Was' and 'Were'

A. Tick (✓) the right option:

1. 'Was' and 'Were' are use for-events.

Ans. (b) past

2. 'Was' is used with-person or thing.

Ans. (a) one

3. 'Were' is used with :

Ans. (b) more

B. Correct the following sentences:

1. We was eating chocolates. We **were** eating chocolates.
2. She were a teacher. She **was** a teacher.
3. I were playing chess. I **was** playing chess.
4. They was not in uniform. They **were** not in uniform.

- | | |
|---------------------------------|------------------------------------|
| 5. The sky were clear. | The sky was clear. |
| 6. The train were late. | The train was late. |
| 7. We was in trouble. | We were in trouble. |
| 8. It were very cold yesterday. | It was very cold yesterday. |
| 9. My sister were in the room. | My sister was in the room. |
| 10. It were a pleasant trip. | It was a pleasant trip. |

C. Fill in the blanks with was or were:

1. It **was** a rainy day.
2. We **were** in the class.
3. They **were** in the cinema hall.
4. Rahul **was** late.
5. There **were** goats in the field.
6. She **was** good in dance.
7. They **were** in the army.
8. Children **were** planting trees.
9. She **was** at the hospital.
10. You **were** not dancing.

D. Answer the following questions:

1. For which events are 'Was' and 'Were' used?

Ans. 'Was' and 'Were' are used for **past events**.

2. Where is 'was' used?

Ans. 'Was' is used with **singular person or thing**.

3. Where do we use 'were'?

Ans. 'Were' is used with **plural persons or things**.

11 Use of 'Has', 'Have' and 'Had'

A. Tick (✓) the right option :

1. 'Has' and 'Have' are used for _____ time.

Ans. (a) Present

2. 'Had' is used for _____ time.

Ans. (b) Past

3. 'Has' is used with :

Ans. (b) He

4. 'Have' is used with :

Ans. (c) They

B. Fill in the blanks with 'has' or 'have' :

1. A box **has** six sides.
2. January **has** thirty-one days.
3. The room **has** three doors.
4. They **have** red pens.
5. We **have** black pencils.
6. I **have** a pet dog.
7. I **have** a five rupee note.
8. They **have** storybooks.
9. She **has** a fine doll.
10. He **has** a bat.

C. Fill in the blanks with 'had' :

1. The cat **had** two kittens.
2. You **had** a black dress.
3. Guava **had** many seeds.
4. I **had** a beautiful watch.
5. They **had** a new car.

D. Answer the following questions :

1. Where is 'have' used?

Ans. 'Have' is used with plural subjects and with I, we, you, they in present time.

2. Write two sentences with have.

Ans.

- I have a book.
- They have a car.

3. Where is 'has' used?

Ans. 'Has' is used with singular subjects like he, she, it, or one person/thing.

4. Write two sentences with has.

Ans.

- She has a pen.
- He has a bag.

5. Where is 'had' used?

Ans. 'Had' is used for past time with all subjects.

6. Write two sentences with had.

Ans.

- I had a bicycle.
- They had a house.

12

Articles ('A', 'An' and 'The')

A. Tick (✓) the right option:

1. Which article is used before 'egg'?

Ans. (b) An

2. Article 'an' will be used before:

Ans. (b) ice cream

3. Which article will be used before 'Ganga'?

Ans. (c) The

B. Fill in the blanks with 'A' 'An' or 'The' :

1. The sun.

02. A lion.

3. An ox.

04. A bus.

5. An aeroplane.

06. A plant.

7. The moon.

08. An ear.

9. A pencil.

10. A leg.

C. Answer the following questions:

1. Where do you use the article 'A'?

Ans. We use 'A' before words that begin with a **consonant sound**.

2. Where do you use the article 'An'?

Ans. We use 'An' before words that begin with a **vowel sound**.

3. Where do you use the article 'The'?

Ans. We use 'The' to refer to a **particular or specific person, place, animal, or thing**.

13 Verbs : Action Words

A. Tick (✓) the right option:

1. Which of the following words is a Verb?

Ans. (b) Runs

2. Which of the following is not a Verb?

Ans. (b) Quickly

3. What is the other name of action words:

Ans. (a) Doing words

B. Fill in the blanks with suitable Verbs:

1. I watched the match.

2. The birds sing sweetly.

3. A tiger runs very fast.

4. They read stories.

5. The boys play football.

6. We drink tea and milk.

7. Ekta speaks English at home.

8. Kamal writes a letter.

C. Underline the Verbs in the following sentences and write them in the given space:

1. Birds build nest.

build

- | | |
|---|-----------------|
| 2. Megha <u>learns</u> her lesson. | <u>learns</u> |
| 3. The Earth <u>moves</u> round the Sun. | <u>moves</u> |
| 4. The teacher is <u>teaching</u> . | <u>teaching</u> |
| 5. Akshay <u>writes</u> a letter. | <u>writes</u> |
| 6. Smita <u>plays</u> with her aeroplane. | <u>plays</u> |
| 7. Cow <u>give</u> us milk. | <u>give</u> |
| 8. I <u>watched</u> the movie. | <u>watched</u> |

D. Answer the following questions:

1. Which words are called verbs?

Ans. Words that show action (what a person, animal or thing does) are called verbs.

2. Write some action words.

Ans. eat, run, write, read, play, jump, sing, dance

14 Prepositions

A. Fill in the blanks with the suitable Prepositions from the brackets :

- The pens are in the bag.
- Biscuits is baked in an oven.
- The rat is in the cupboard.
- The pencil is on the book.
- The bee is on the sweet.
- The boy jumps over the fence.
- The baby is in the car.
- The monkey is climbing up the tree.

B. Underline the Prepositions in the following sentences :

- | | |
|---------------------------------------|---------------------------------------|
| 1. The car is <u>on</u> the road. | 2. The cat is <u>under</u> the table. |
| 3. The man is <u>behind</u> the door. | 4. The cup is <u>above</u> the table. |

5. The child is **in front of** the house.

C. Answer the following questions :

1. Which words are called Prepositions?

Ans. Prepositions are words that tell the position of a person, animal, or thing.

2. Give some examples of Prepositions.

Ans. **Examples-** on, in, under, near, between, behind, across, among, up, in front of

15 Conjunctions : Joining Words

A. Tick (✓) the right option :

1. Conjunctions are also called :

Ans. (a) joining words

2. The word which joins two words, is called :

Ans. (b) Conjunction

3. Which of the following is a Conjunction?

Ans. (c) and

B. Fill in the blanks with the suitable Conjunctions :

1. Ram **and** Rohit are playing.

2. Work hard **or** you will fail.

3. Shall they walk **or** run?

4. She is old **but** polite.

5. Keep quiet **or** go out.

6. The jungle is big **and** dense.

7. He is poor **but** not happy.

8. I will say **if** you keep quiet.

C. Joint the sentences together by using and, but, or and because :

1. The pencil is lost. It is stolen.

Ans. The pencil is lost because it is stolen.

2. Is the tea hot? Is the tea cold?

Ans. Is the tea hot or cold?

3. The man is thin. He is tall.

Ans. The man is thin but he is tall.

4. My sister is wise. My brother is wise.

Ans. My sister is wise and my brother is wise.

5. Does he like cricket? Does he like badminton?

Ans. Does he like cricket or badminton?

D. Underline the Conjunctions in the following sentences :

1. She failed because she did not study hard.

2. Keep quite or go out.

3. I know that he is honest.

4. He was sleeping when she came to meet him.

5. Though she is poor, she is happy.

6. Nobody will believe him, if he tells lies.

7. He waited for him until he came back.

8. The lady was polite and pretty.

9. Neha is fat but Kirti is thin.

10. Will he wait till I return?

E. Answer the following questions :

1. What is the use of Conjunctions?

Ans. Conjunctions are used to join words, groups of words, or sentences.

2. Write some words of Conjunctions.

Ans. and, but, or, because, if, when, though, until, etc.

16

Use of 'This' and 'That'

A. Tick (✓) the right option:

1. _____ is used to describe a thing nearby, indicated by the finger.

Ans. (a) This

2. _____ is used to describe a thing at a little distance, indicated by the finger.

Ans. (b) That

B. Fill in the blanks with 'This' and 'That' :

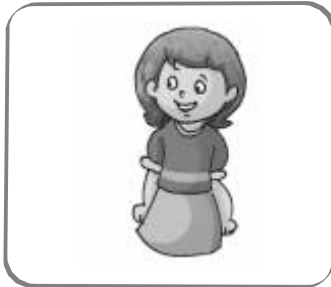

This is a girl.

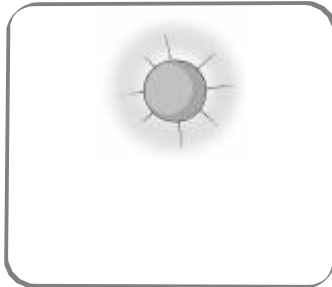

That is a sun.

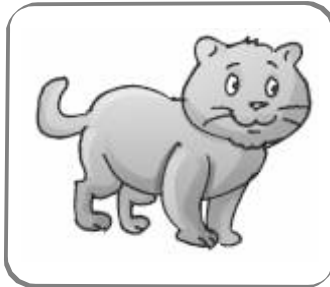

This is a cat.



That is a dog.

C. Answer the following questions :

1. Where is this used?

Ans. 'This' is used to describe a thing nearby.

2. Where is that used?

Ans. That' is used to describe a thing at a little distance.

17 Punctuations

A. Tick (✓) the right option :

1. To separate many Nouns in a sentence, we use :

Ans. (b) Comma

2. The first letter of a sentence begins with :

Ans. (a) Capital letter

B. Fill in the blanks :

- 'I' is always written in **capital** letter.
- A Full stop is put at the **end** of a sentence.
- There are **two** types of letters in English script.

4. The name of country begin with **capital** letter.

C. Put Commas at the right place in the following sentences :

1. Megha is wise intelligent and beautiful girl.

Ans. Megha is wise, intelligent and beautiful girl.

2. December January and February are the cold months.

Ans. December, January and February are the cold months.

3. He is intelligent hard working and loving person.

Ans. He is intelligent, hard working and loving person.

4. We study Hindi English Mathematics and Science in our school.

Ans. We study Hindi, English, Mathematics and Science in our school.

D. Rewrite these sentences using Capital letters, Question mark and Full stop where necessary :

1. do not make a noise

Ans. Do not make a noise.

2. kalidas was a great poet of india

Ans. Kalidas was a great poet of India.

3. there is a large crowd in the stadium

Ans. There is a large crowd in the stadium.

E. Answer the following questions:

1. What is called Punctuation?

Ans. Punctuation is the use of comma, full stop, capital letters, etc. in sentences.

2. Where is Full stop (.) used?

Ans. A full stop is used at the end of a sentence.

3. Where are Capital letters used?

Ans. Capital letters are used at the beginning of a sentence and for important names like days, months, places, people, etc.

18

Use of 'These' and 'Those'

A. Tick (✓) the right option :

1. _____ is used for plural things which are near.

Ans. (c) These

2. _____ is used for plural things which are far.

Ans. (b) Those

B. Fill in the blanks with These and Those :

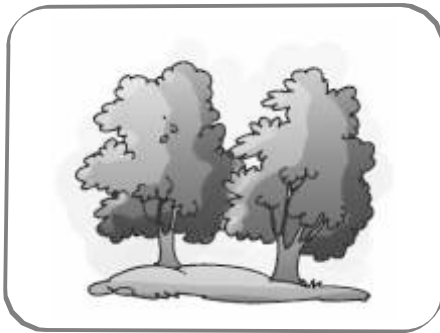

Those are trees.

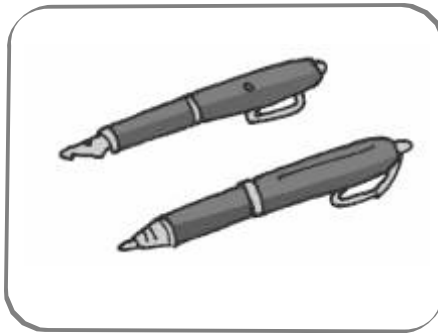

These are pens.

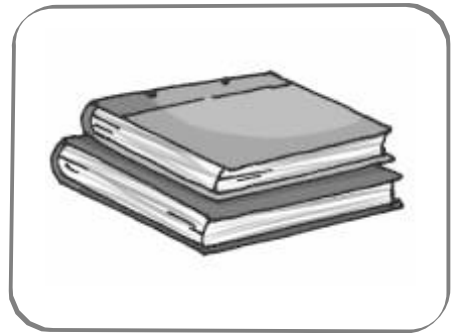

These are books.

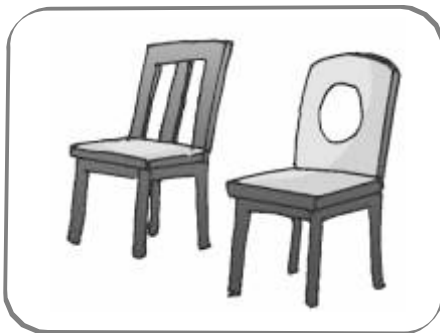

These are chairs.

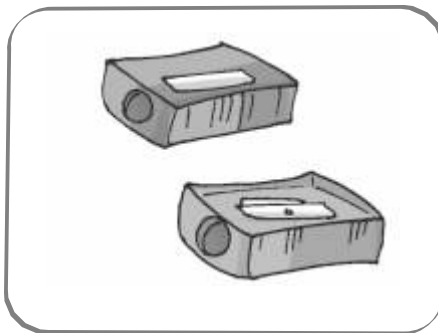

These are shopper.

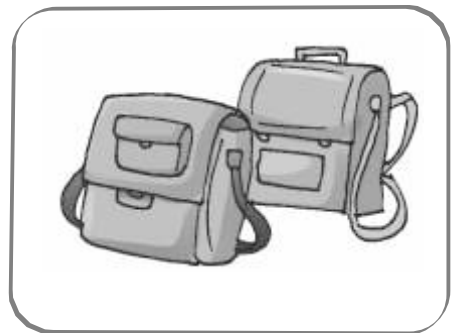

Those are bags.

C. Answer the following questions :

1. Where is These used?

Ans. These is used for many persons, places or things which are near.

2. Where do we use Those?

Ans. Those is used for many persons, places or things which are far.

19 Application Writing

1. **Write an application to your Principal for leave due to sickness.**

To, The Principal

E.G.P. School,

Agra,

Sir,

Most respectfully, I beg to say that I am a student of Class I-B in your school. I am suffering from fever and the doctor has advised me to take rest for two days.

Kindly grant me leave for two days. I shall be highly thankful to you.

Yours obediently

Raj Sharma

Class I-B

2. **Write an Application to your Principal to arrange a cricket coach.**

To,

The Principal

Rainbow Public School

Meerut

Sir,

Most respectfully, I want to say that we students are very interested in playing cricket. But we do not have a proper coach to guide us. So, I request you to kindly arrange a cricket coach for us so that we can improve our game.

Yours obediently

Aakash Verma

Class I-C

3. Write an Application to your Principal for TC.

To,
The Principal
Divya Public School,
Roorkee
Sir,

Most respectfully, I beg to say that my father has been transferred to another city. So, I will not be able to continue my studies in your school. Therefore, I request you to kindly issue my Transfer Certificate.

Yours obediently
Nishant Jain
Class I-A

20 Questions

A. Write 'Yes' or 'No' :

- | | |
|---------------------------|-----|
| 1. Do you like bananas? | Yes |
| 2. Do you like ice cream? | Yes |
| 3. Do you like drawing? | Yes |
| 4. Do you like skipping? | Yes |
| 5. Do you like chess? | Yes |
| 6. Can an aeroplane fly? | Yes |
| 7. Can dog talk to you? | Yes |
| 8. Can a car run fast? | Yes |
| 9. Can a cat give milk? | Yes |
| 10. Can a rat fly? | No |

B. Answer the following questions. Use the pictures as clues :

1. What is this?
This is a **kite**.



2. Who is she?
She is a **nurse**.
3. What is this?
This is a **bat**.



- C. Answer the following questions:
Do it yourself.

21 Story Writing

- A. Write a story of 'A Rabbit and a Tortoise'.

Once there was a rabbit and a tortoise. The rabbit was very proud of his speed. He always made fun of the slow tortoise. One day, the tortoise challenged the rabbit to a race. The rabbit laughed but agreed.

The race started. The rabbit ran very fast and soon went far ahead. He thought the tortoise was too slow, so he decided to take a nap under a tree. Meanwhile, the tortoise kept walking slowly but steadily.

After some time, the rabbit woke up and saw that the tortoise was near the finish line. He ran as fast as he could, but it was too late. The tortoise won the race.

Moral: Slow and steady wins the race.

- B. Write your favourite story.

Do it yourself.

- C. Fill in the blanks with the proper words given in the box:

One day it was very **hot**. A **lion** was sleeping under a tree. A **mouse** came there. It **jumped** upon the lion. The lion **woke** up. He was very **angry**. He **caught** the mouse and said, "I will kill you." The mouse **requested**, "Let me go. I can help you in future." The lion agreed. One day, the lion was caught in a **net**. The mouse **nibbled** the net. The lion was **free**. He **thanked** the mouse.

22 Comprehension

Write the correct answer :

1. A **tiger** had seen the magician take out a rabbit from the hat.
2. The tiger came up to the **magician** and growled loudly.
3. "Take out a **cub** from the hat for me", shouted the tiger.
(kitten/cub)
4. The poor magician shook with **fear**.

Tick (✓) the correct answer:

1. Pinki loved:

Ans. (a) To read

2. What did Pinki do first?

Ans. (b) See the pictures

3. How did she know what the book or passage was about?

Ans. (c) Reading the title

4. What did she do as she read?

Ans. (a) Made pictures in her mind about what she read

Fill in the blanks:

1. Just then a **mosquito** went round and round the elephant's head.
2. He tried to hit the mosquito with his **trunk**.
3. If the mosquito goes into my **ear**, it will hurt me!
4. How can a mosquito hurt the elephant, just **think** about it.

1

The Sentence

Grammar-2

A. Tick (✓) the right option :

1. A Sentence is a group of words which makes _____.

Ans. (ii) complete sense

2. Each sentence begins with _____.

Ans. (ii) a capital letter

B. Arrange the following groups of words to make sentences. The first one has been done for you:

1. a has wheels car four

A car has four wheels.

2. a fruit a is mango

A mango is a fruit.

3. to are girls going school the

The girls are going to school.

4. nests trees build birds in

Birds build nests in trees.

5. i a saw dog

I saw a dog.

6. a song sings he

He sings a song.

C. Match List 'A' with List 'B' to make sentences :

List 'A'

List 'B'

1. The little boy

(d) **is crying.**

2. Neetu likes

(a) **to eat ice cream.**

3. The stars

(b) **are shining.**

4. The Sun

(f) **rises in the east.**

5. The carpenter

(c) **is making a table.**

6. Ice cream

(e) **tastes sweet.**

2

Parts of Speech

A. Tick (✓) the right option :

1. _____ is the name of a person, thing, animal or place.

Ans. (ii) Noun

9. A large **crowd** of people gathered in the street.
10. An **army** consists of soldiers and commanders .

D. Arrange the following words in their respective columns :

| Ans | Proper Nouns | Common Nouns |
|------------|---------------------|---------------------|
| | Indira Gandhi Nepal | orange grass salt |
| | Sahara Tokyo Ganga | table tiger monkey |
| | Big Ben Islamabad — | boy |

E. Encircle the peoper nouns and underline the common nouns :

1. The (Sun) rises in the east.
2. (Mumbai), (Chennai) and (Kolkata) are important ports of (India).
3. (Sachin) is a player.
4. (Mayank) lives in (Meerut).
5. Lion is the king of forest.
6. Dogs bark at the thieves.
7. (Aadi) is a doctor.
8. The police helped the passengers.

F. Pick out the abstract nouns from the following sentences and write them in the space provide:

- | | |
|------------------------------------|-------------------------|
| 1. He is proud of his wisdom. | <u>wisdom</u> |
| 2. Always speak the truth. | <u>truth</u> |
| 3. He is known for his honesty. | <u>honesty</u> |
| 4. Wisdom is better than strength. | <u>wisdom, strength</u> |
| 5. Books give us knowledge. | <u>knowledge</u> |
| 6. Love is blind. | <u>love</u> |
| 7. He is showing good progress. | <u>progress</u> |
| 8. My uncle had pain in the leg. | <u>pain</u> |

G. Answer the following questions:

1. Define proper noun.

Ans. A proper noun is the name of a particular person, place, or thing.

2. What is abstract noun? Give examples.

Ans. An abstract noun is the name of a quality, feeling, or state that cannot be seen or touched.

Examples: honesty, love, courage

3. What is the definition of common noun?

Ans. A common noun is a general name of a person, place, animal, or thing.

4. Write the definition of collective noun?

Ans. A collective noun is the name of a group of persons or things taken as one.

4

Nouns: Singular and Plural

A. Tick (✓) the right option :

1. Any Noun that stands for only one person, is said to be in the _____ number.

Ans. (a) Singular

2. Any Noun that stands for more than one person, is said to be in the _____ number.

Ans. (b) Plural

3. A Pronoun is said to be in the Singular Number when it stands for :

Ans. (a) one person

4. A Pronoun is said to be in the Plural Number when it stands for :

Ans. (b) two persons

B. Fill in the blanks with the Plural form of the word given in the brackets:

1. There are many animals in the zoo. (animal)

2. I saw two deer in the park. (deer)

3. There are four rooms in my house. (room)

4. Many cats were running in the park. (cat)

C. Fill in the blanks with missing words in the following table :

| Singular | Plural | Singular | Plural | Singular | Plural |
|-------------|--------|----------|--------------|-------------|--------------|
| chair | chairs | foot | <u>feet</u> | <u>calf</u> | calves |
| <u>lady</u> | ladies | fox | <u>foxes</u> | woman | <u>women</u> |

hair
baby
cow

hair
babies
cows

goose
child
cup

geese
children
cups

city
mouse
toy

cities
mice
toys

D. Write the Plural of the following words :

| | | | | | |
|-------|--------------|------|--------------|-------|----------------|
| sheep | sheep | news | news | knife | knives |
| mouse | mice | box | boxes | mango | mangoes |

E. Give the Plural of the following words :

| | | | | | |
|-------|---------------|--------|-----------------|-------|---------------|
| wolf | wolves | boot | boots | river | rivers |
| house | houses | potato | potatoes | baby | babies |
| lake | lakes | bush | bushes | foot | feet |

F. Give the Singular of the followings words :

| | | | | | |
|----------|--------------|----------|---------------|------------|-----------------|
| oxen | ox | matches | match | mosquitoes | mosquito |
| deer | deer | mice | mouse | watches | watch |
| children | child | branches | branch | trees | tree |

G. Answer the following questions :

1. What do you understand by the Singular Number?

Ans. A noun that stands for only one person, animal, place or thing is called Singular Number.

2. What do you understand by the Plural Number?

Ans. A noun that stands for more than one person, animal, place or thing is called Plural Number.

5

Nouns : Gender

A. Tick (✓) the right option :

1. Word that denotes a male is said to be of the :

Ans. (ii) masculine gender

2. Word that denotes both a male and female is said to be of the :

Ans. (iii) common gender

B. Fill in the blanks with the correct male or female naming word:



A boy and a girl.



An ox and a cow.



A servant and a maid.



A lion and a lioness.



An actor and an actress.



A king and a queen.

C. Fill in the blanks with feminine/masculine words for the words in colour.

1. My nephew loves me. My niece also loves me.
2. My brother is reading and my sister is playing.
3. My mother is a doctor but my father is a teacher.
4. The king bowed to the queen.
5. A bride and a bridegroom are dancing.
6. The princess saved the prince from a lion.
7. The peacock was dancing and the peahen was sitting in the field.
8. Akshay Kumar is an actor and Deepika is an actress.

C. Underline the masculine words and encircle the feminine words.

1. The mayor went to see the king.
2. (Raj) met his friend Diya in the office.
3. The (maid) is sweeping the floor.

4. The bride was looking smart.
5. His brother greeted the lady.
6. My mother invited my uncle for dinner.
7. She welcomed her guests.
8. How many brothers and sisters do you have ?
9. We saw elephants and zebra in the circus.
10. He has three sons and a daughter.

D. Write M for masculine and F for feminine :

- | | | | |
|-------------|----------|----------|----------|
| 1. tigress | F | 2. bull | M |
| 3. daughter | F | 4. sir | M |
| 5. father | M | 6. horse | M |
| 7. king | M | 8. fox | M |
| 9. lion | M | 10. aunt | F |
| 11. ox | M | 12. lord | M |

6

Pronoun and Its Kinds

A. Tick (✓) the right option:

1. Words which are used in place of nouns are called:
 - (ii) pronouns
2. Which of the following words is a pronoun?
 - (iii) He
3. Pronouns which are used to point out the object or objects to which it refers, are called:
 - (i) demonstrative

B. Use pronouns in place of the coloured nouns:

1. Shiv and Raj are brothers. Shiv and Raj are my cousins.
Shiv and Raj are brothers. **They** are my cousins.

2. Mayank was happy. *Mayank* have won a prize.
Mayank was happy. **He** has won a prize.
3. Megha is a teacher. *Megha* loves us.
Megha is a teacher. **She** loves us.
4. Preeti has several books. The books contain stories. But Preeti does not give her books to anyone.
Preeti has several books. The books contain stories. But **she** does not give **them** to anyone.

C. Encircle the pronouns in the following sentences and say whether they are personal, demonstrative, interrogative or reflexive pronouns. First one has been done for you :

- | | |
|---------------------------|------------------------------|
| 1. (I) am going itself. | Personal Pronoun |
| 2. The cat hurt (itself). | Reflexive Pronoun |
| 3. (Which) is your chair? | Interrogative Pronoun |
| 4. (These) are pens. | Interrogative Pronoun |
| 5. (Whom) did you meet? | Interrogative Pronoun |

D. Tick (✓) the correct pronoun given in the bracket:

1. I shall invite (she[✓], her) to our house.
2. They enjoyed (them, themselves[✓]) very much.
3. I have seen (he, him[✓]) several times.
4. Mohit and (me, I[✓]) went to meet (they, them[✓]).
5. It is (me, I[✓]).

E. Pick out the pronouns from the following sentences :

- | | |
|--|-----------------|
| 1. Kamal's father presented him a car. | him |
| 2. Please tell us a story. | us |
| 3. She loves her mother. | she, her |
| 4. Rohit is my cousin. | my |
| 5. We like music. | we |

F. Answer the following questions:

1. Which words are called pronouns?

Ans. Words that are used in place of nouns are called pronouns.

2. What are the persons of pronoun?

Ans. There are three persons of pronouns:

- First Person (I, we, me, us)
- Second Person (you)
- Third Person (he, she, it, they, him, her, them)

7

Adjectives

A. Tick (✓) the right option :

1. Words which describe Nouns or Pronouns are called :
(b) Adjectives
2. Adjectives are also called :
(b) Describing words
3. Which of the following is an Adjective?
(c) bad
4. Most adjectives have _____ degrees of comparison.
(b) three

B. Fill in the blanks with suitable Adjectives :

1. Ashoka was a **great** king.
2. A giraffe has a **long** neck.
3. The Sun is a **hot** ball of fire.
4. We should be **kind** to animals.
5. Bhagat Singh was a **brave** personality.
6. Aman is a **good** boy.
7. The horses are **fast**.
8. The elephant is a very **big** animal.
9. The leaves are **green**.
10. Jaipur is a **beautiful** city.

C. Pick out the Adjectives in the following sentences :

- | | |
|--|---------------|
| 1. Neelu is a good girl. | good |
| 2. Abhinav has new gun. | new |
| 3. Delhi is a big city. | big |
| 4. Manvi had four balloons. | four |
| 5. The cow is a useful animal. | useful |
| 6. Chandra Shekhar Azad was a great personality. | great |
| 7. The flowers smell sweet. | sweet |
| 8. The old man walked slowly. | old |
| 9. Lord Rama was a wise king. | wise |
| 10. The mangoes are sweet. | sweet |

D. Answer the following questions :

1. What is called Adjective?

Ans. Words that describe nouns or pronouns are called Adjectives.

2. What are the degrees of comparison in Adjective?

Ans. There are three degrees of comparison:

8

Adverb and Its Kinds

A. Tick (✓) the right option:

1. _____ is a word that adds something to the meaning of a verb, an adjective or another adverb:

Ans. (ii) Adverb

2. Slowly, sweetly and fast are:

Ans. (iii) adverbs of manner

3. Yesterday, late and soon are:

Ans. (iii) adverbs of time

4. Here and upstairs are the adverbs of:

Ans. (ii) place

B. Write the Adverbs of Manner in front of the following sentences:

- | | |
|---------------------------------|----------------|
| 1. My dog runs fast. | fast |
| 2. The old woman walks slowly. | slowly |
| 3. He treated us kindly. | kindly |
| 4. We won the match easily. | easily |
| 5. The soldiers fought bravely. | bravely |
| 6. She ran quickly. | quickly |
| 7. Nitu sang sweetly. | sweetly |
| 8. The girl worked hard. | hard |

C. Write the Adverbs of Time in front of the following sentences:

- | | |
|---------------------------------|------------------|
| 1. We get up early. | early |
| 2. We go to bed late. | late |
| 3. He came yesterday. | yesterday |
| 4. I shall teach you tomorrow. | tomorrow |
| 5. She will come soon. | soon |
| 6. They always speak the truth. | always |
| 7. I never tells a lie. | never |
| 8. They have not come today. | today |

D. Write the Adverbs of Place in front of the following sentences:

- | | |
|---|-------------------|
| 1. I looked up. | up |
| 2. We lived here. | here |
| 3. She has gone upstairs. | upstairs |
| 4. I am sitting inside. | inside |
| 5. They have gone away. | away |
| 6. Go two steps backward. | backward |
| 7. The sky is above. | above |
| 8. He has looked for the book everywhere. | everywhere |

E. Answer the following questions :

1. Write the definition of adverb?

An adverb is a word that adds something to the meaning of a verb, an adjective or another adverb.

2. Write the name of kinds of adverbs.

- Ans.**
- Adverbs of Manner
 - Adverbs of Time
 - Adverbs of Place

3. Write some words of adverbs of manner.

Ans. slowly, quickly, happily, sweetly

4. Write some words of adverbs of time.

Ans. yesterday, today, tomorrow, early, late

5. Write some words of adverbs of place.

Ans. here, there, upstairs, downstairs, above

9

Countable and Uncountable Nouns

A. Encircle the food items that can be counted and underline the food items that cannot be counted :



sand



butter



mangoes



oranges



cooking oil



bananas



ice



grapes



stars



eggs



moon

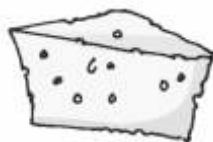

cheese



milk



sugar



peas

B. Underline the countable or uncountable words in the following sentences. Write in the correct boxes.

1. My brother likes mangoes.
2. The children are having a lot of fun.
3. Some children are playing in the park.
4. Give me your book, please.
5. The wind is very strong.
6. I have two pens.
7. They sat round the fire.
8. The traffic on the road is heavy.



| Countables | | Uncountables | |
|-------------|-----------|--------------|-------------|
| 1. mangoes | Countable | 2. fun | Uncountable |
| 3. children | Countable | 5. wind | Uncountable |
| 4. book | Countable | 7. fire | Uncountable |
| 6. pens | Countable | 8. traffic | Uncountable |

C. Sort out the uncountable in each sentence and write it in the blank:

1. Doctor is in the room. —
2. I take milk in breakfast. milk
3. Rice is cooked before it is eaten. rice
4. I take tea in the evening. tea
5. Cows eat grass. grass
6. Children are making a noise. noise
7. Cement is used in construction. cement
8. I like mangoes very much. —

D. Look at the pictures given below. Colour the circles near the things that are countable red and those that are uncountable green

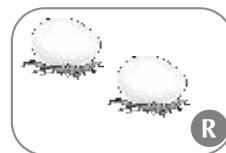
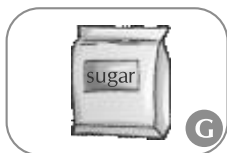
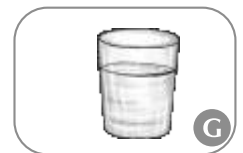
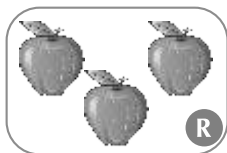

10 Verbs

A. Tick (✓) the right option :

1. Which of the following verbs is singular?

Ans. (a) goes

2. Verbs are also called :

Ans. (a) doing words

3. Verb often consists more than _____ word.

Ans. (a) one

B. Here are some naming words (Nouns) and doing words (Verbs). Match the right doing words with each naming word :

| Noun | Verb |
|------------------|-------------|
| 1. The batsman | (b) hits |
| 2. The aeroplane | (e) flies |
| 3. The rain | (g) falls |
| 4. The cat | (a) meows |
| 5. The priest | (c) prays |
| 6. The painter | (d) paints |
| 7. The teacher | (h) teaches |
| 8. The knife | (f) cuts |

C. Pick out the Verbs in the following sentences :

| | |
|---------------------------------------|-----------|
| 1. Doctors are going to meeting hall. | are going |
| 2. The mother teaches her child. | teaches |
| 3. They purchased a new bike . | purchased |
| 4. Prem has blue shoes. | has |
| 5. Radha has brown eyes. | has |
| 6. They had two ears. | had |

D. Answer the following questions :

1. What are Verbs?

Verbs are action words or doing words. They tell what a person, animal or thing does, is doing or has done.

2. Write some words of Verbs.

run, eat, play, write, jump, read, sing, climb

11

Verbs

A. Write Conjunction in the following sentences :

1. Ekta sang and Neetu danced.
2. Seema failed because she did not work hard.
3. She will pass if she works hard.
4. He is poor but he is happy.
5. Do not run fast lest you should fall.
6. Come in or go out.

and

because

if

but

lest

or

B. Join the pairs of words as given below in the examples:

Far **and** near.

Hard **and** fast.

Sita **and** Gita.

Rough **and** tough.

The cow **and** the calf.

High **and** low.

Man **and** his son.

A boy **and** a girl.

C. Join these pairs of sentences using 'and' or 'but' :

1. This mango is sweet. That one is sour.
This mango is sweet **but** that one is sour.
2. A fly is an insect. An ant is an insect also.
A fly is an insect **and** an ant is an insect also.
3. This knife is sharp. That one is blunt.
This knife is sharp **but** that one is blunt.
4. An apple is a fruit. An onion is a vegetable.
An apple is a fruit **and** an onion is a vegetable.
5. This plate is dirty. That one is dirty also.
This plate is dirty **and** that one is dirty also.
6. My father is rich. His father is poor.
My father is rich **but** his father is poor.

7. Sunday is a holiday. Monday is a holiday also.
Sunday is a holiday **and** Monday is a holiday also.
8. He is tall. His sister is short.
He is tall **but** his sister is short.

D. Answer the following questions :

1. Write the definition of conjunction?

Ans. A conjunction is a word which is used to join words, groups of words, or sentences.

2. Write some words of conjunctions?

Ans. **Examples:** and, but, because, or, if, lest

12

Interjections

A. Tick (✓) the right option :

1. The word which expresses some sudden feelings of the mind, is called:

Ans. (c) Interjection

2. Which of the following is an Interjection?

Ans. (c) Bravo

3. The word 'Hurrah' expresses sudden :

Ans. (a) joy

B. Fill in the blanks with the Interjections :

1. **Shh**! The girl is sleeping.
2. **Hurrah**! Sagar has won!
3. **Bravo**! You have done well.
4. **Oh**! What are you doing here?
5. **Alas**! I have lost my dog.

C. underline the Interjection in these sentences :

- | | |
|------------------------------------|--|
| 1. <u>Oh</u> ! Look at the moon. | 2. <u>Alas</u> ! My dog is dead. |
| 3. <u>Bravo</u> ! what a goal? | 4. <u>Ouch</u> ! I have burnt my leg. |
| 5. <u>Shh</u> ! You will wake him. | 6. <u>O dear</u> ! The dogs are barking. |

D. Match the Interjections in Column A with a sentence each in Column B to make meaningful sentences :

Column 'A'

1. What!
2. Hush!
3. Hurrah!
4. Oh!
5. Hallo!

Column 'B'

- (d) You are again late.
- (e) The baby is asleep.
- (c) I have won the first prize.
- (b) A wonderful hit.
- (a) How are you?

E. Answer the following questions :

1. Which words are called Interjections? What do they show?

Ans. Interjections are words that express sudden feelings or emotions of the mind. They show feelings like joy, surprise, sorrow, pain, or greeting.

2. Write some words of Interjections.

Ans. Hurrah, Wow, Oh, Alas, Bravo, Hello, Ouch, Shh.

13 Prepositions

A. Tick (✓) the right option :

1. I ran _____ the bus.

Ans. (ii) after

2. She jumped _____ a river.

Ans. (ii) into

3. The cover _____ this book is dirty.

Ans. (ii) of

4. A fan is hung _____ my head.

Ans. (iii) over

5. The ball lies _____ the table.

Ans. (iii) on

B. Choose the correct preposition from the brackets and fill in the blanks :

1. He is proud of his son.
2. I go to school daily.

3. Ravi is standing **at** the gate.
4. Open your book **at** page 36.
5. He came **into** the room.
6. I will not go there **with** you.
7. There is a shop **in front of** my house.
8. The servant knocked **at** the door.

C. Make sentences using the following prepositions and pictures:

1. between - **The ball is between the two boxes.**
2. behind - **The boy is behind the door.**
3. under - **The cat is under the table.**
4. in front of - **The car is in front of the house.**
5. outside - **The dog is outside the house.**



D. Fill in the blanks with the suitable preposition given in the box:

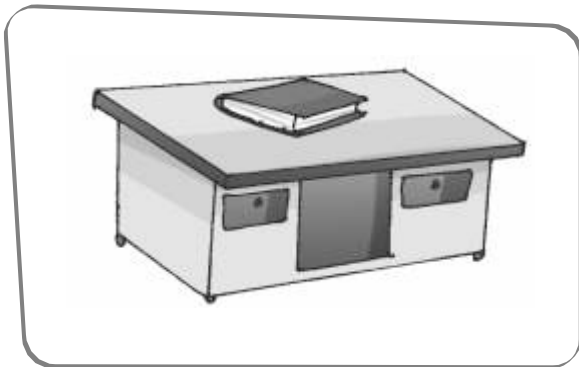

The book is **on** the table.

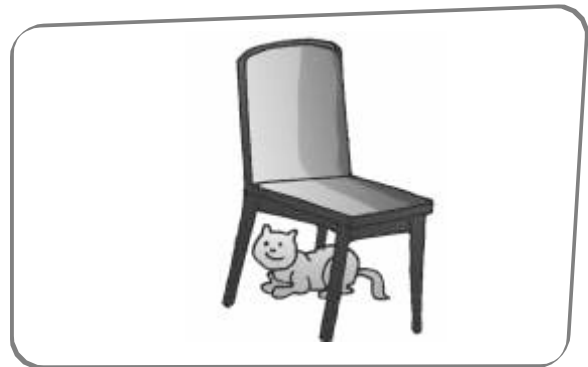

The cat is **under** the chair.

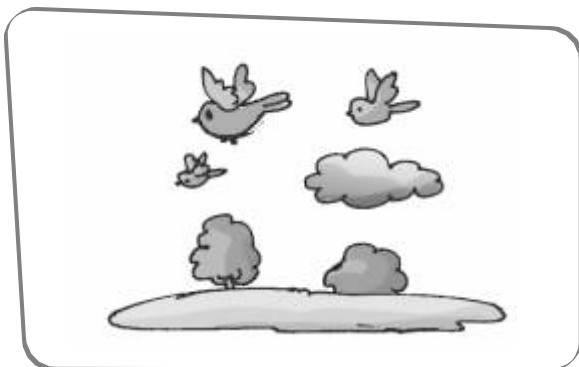

The birds fly **in** the sky.

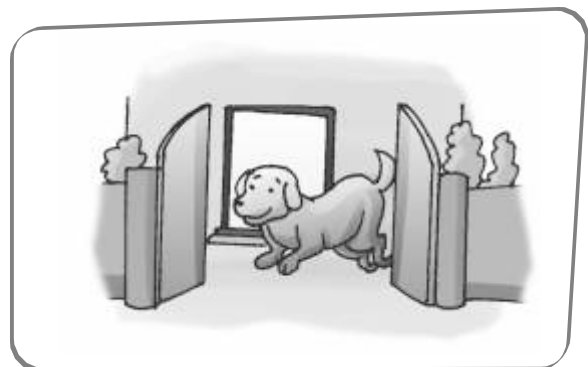

The dog is **behind** the door.



The leaves are falling **from** the tree.

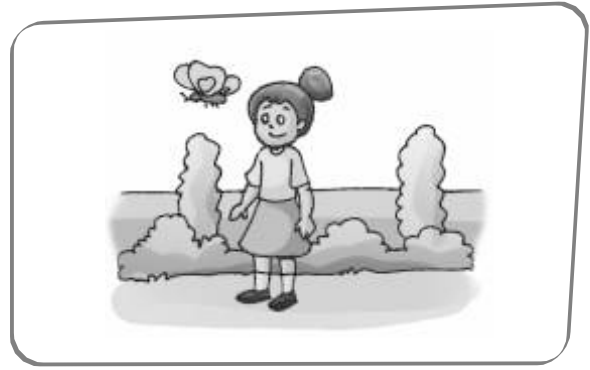

The butterfly is **above** the girl's head.

E. Answer the following questions :

1. Write the definition of preposition?

Ans. A preposition is a word that shows the relation between a noun or pronoun and other words in a sentence.

2. Write some words of prepositions?

Ans. in, on, under, behind, above, between, near, into, across, beside, with

14 Opposites

A. Complete the second sentence of each pair of sentences with a suitable opposite word from the box:

1. That woman is not young. She is **old**.
2. A car runs not slow. It runs **fast**.
3. The butter is not hard. It is **soft**.
4. The milk was not hot. It was **cold**.
5. The mouse is not a big animal. It is **small**.
6. The box is not light. It is **heavy**.
7. Mr. Garg is not foolish. He is **wise**.
8. He is not a poor man. He is **rich**.
9. This house is not big. It is **small**.
10. The shirt is not long. It is **short**.

B. Fill in the blanks with the opposites for the words given in colour. Choose the words from the box:

1. Silver is cheap, but diamonds are **costly**.

2. Streets are narrow, but roads are wide.
3. Grapes were sour, but mangoes were sweet.
4. It is not true, it is false.
5. Some sums were difficult, but others were easy.
6. The shoes are old but socks are new.
7. His shoes are dirty but his clothes are clean.
8. Sachin is rude but Sahil is polite.

15

Articles : A, An and The

A. Tick (✓) the right option :

1. The words 'A', 'An' and 'The' are called :
(b) Articles
2. The word 'The' is called :
(b) Definite Article

B. Fill each blanks with 'A' and 'An' :

1. An oak and an acorn.
2. An egg and a spoon.
3. An orange and a banana.
4. An animal and a bird.
5. A year and a month.

C. Fill in the blanks, using 'A', 'An' or 'The' as required :

1. He was late by an hour.
2. Gold is a precious metal.
3. Rahul bought a book.
4. He bought a cow, an ox and a buffalo.
5. The Himalayas are the highest mountains in the world.

D. Answer the following questions :

1. What are Articles? What are the kinds of Articles?

Ans. Articles are words like 'A', 'An', and 'The' used before nouns.
There are two kinds of articles:

- Indefinite Articles – A, An
 - Definite Article – The
2. What is Indefinite Article? Where is it used?
 'A' and 'An' are called **Indefinite Articles**.
 They are used to refer to a **general person or thing**.
- 'A' is used before consonant sounds
 - 'An' is used before vowel sounds
3. What is Definite Article? Where is it used?
- 'The' is called the Definite Article.
 - It is used to refer to a specific or particular person, place, or thing.

16

Punctuation

A. Tick (✓) the right option :

1. Full stop is used _____ of a sentence.
 (iii) at the end
2. Question mark (?) is used to end :
 (ii) a question
3. The first word of a sentence begins with a _____ .
 (ii) capital letter

B. Punctuate the following sentences using capital letters and other punctuation marks where necessary :

1. the sun sets in the west

Ans. The sun sets in the west.

2. high and low rich and poor wise and foolish must all die

Ans. High and low, rich and poor, wise and foolish must all die.

3. no i cannot do this work

Ans. No, I cannot do this work.

4. how beautiful the picture is

Ans. How beautiful the picture is!

5. munish ramesh neelu sudhir and rachna are going to mumbai

Ans. Munish, Ramesh, Neelu, Sudhir and Rachna are going to Mumbai.

6. the neighbouring countries of india are nepal bhutan sri lanka china and pakistan

Ans. The neighbouring countries of india are Nepal, Bhutan, Sri Lanka, China and Pakistan.

7. What do you want today

Ans. What do you want today?

17 Punctuation

A. Make the following sentences negative :

- | | |
|----------------------------|--------------------------------|
| 1. He is well. | He is not well. |
| 2. They were hungry. | They were not hungry. |
| 3. He has four pencils. | He has no pencils. |
| 4. They will help you. | They will not help you. |
| 5. I have an English book. | I have no English book. |
| 6. You are idle. | You are not idle. |

B. Make the following sentences negative. The first has been done for you.

1. Sit down

Ans. You are not idle.

2. Open your book.

Ans. Do not open your book.

3. Get up early.

Ans. Do not get up early.

4. Shut the door.

Ans. Do not shut the door.

5. Try your best.

Ans. Do not try your best.

6. Stand up.

Ans. Do not stand up.

C. Turn the following negative sentences into positive sentences:

1. The elephant was not mad.

Ans. The elephant was mad.

2. I cannot understand this thing.

Ans. I can understand this thing.

3. He was not present yesterday.

Ans. He was present yesterday.

4. My mother has no daughter.

Ans. My mother has a daughter.

5. He is not a carpenter.

Ans. He is a carpenter.

18 Interrogative Sentences

A. Change the given statements into questions :

1. The milk is sweet.

Is the milk sweet?

2. They are drawing.

Are they drawing?

3. Your clothes were dirty.

Were your clothes dirty?

4. He has sold his car.

Has he sold his car?

5. They are playing.

Are they playing?

6. The birds are on the tree.

Are the birds on the tree?

19 Short Forms

A. Match both the columns:

A

that is

what is

where is

is not

was not

B

that's

what's

where's

isn't

wasn't

A

have not

should not

they are

I am

I will

B

haven't

shouldn't

they're

I'm

I'll

it is
who is

it's
who's

are not
will not

aren't
won't

B. Write these short forms in full :

you'll **you will**

I'll **I will**

don't **do not**

won't **will not**

he's **he is**

she's **she is**

hasn't **has not**

they're **they are**

I'm **I am**

that's **that is**

you've **you have**

we're **we are**

C. Some words are given within brackets. Fill in the blanks with their short forms. Choose word from the box.

1. Flowers don't live long when we pluck them.
2. One morning, Aman didn't see any butterfly in the garden.
3. Diya now remembers her promise and doesn't pluck flowers.
4. The room isn't looking good, she thought.
5. The fairy told Chinki that we mustn't pluck flowers.
6. It's good for the flower and the plant too.

FORMING NEW WORDS

D. Join the words in the first box with the names of the pictures in the second box. Write the new words on the blanks:

rain

+



bow

>

rainbow

butter

+



fly

>

butterfly

friend

+



ship

>

friendship

news

+

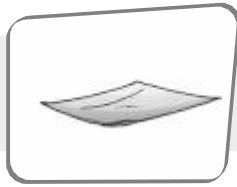

paper

>

newspaper

post

+



office

>

postoffice

pine

+

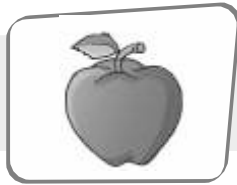

apple

>

pineapple

sun

+

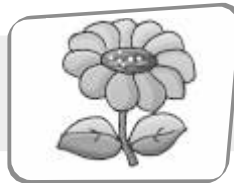

flower

>

sunflower

lady

+



finger

>

ladyfinger

pea

+



cock

>

peacock

foot

+



ball

>

football

20 Story Completion

I. Complete the story by filling the words given below:

THE CLEVER MONKEY

Once two cats were fighting over a piece of bread. A monkey saw them. He said he would divide the bread equally for them. He brought a weighing scale and tore the bread into two. He put one piece on each side. The monkey was very clever. He had kept one piece bigger than the other. He took away a small portion from the bigger piece and quickly ate it up. He did this again and again till the bread was finished. The foolish cats were left hungry.

II. Complete the story by filling the words given below:

A CAMEL AND A JACKAL

A camel and a jackal were friends. Both of them lived on the bank of a river. One day the jackal said to the camel, "Let us go to the sugar cane farm on the other side of the river". But the jackal did not know swimming. So the camel carried jackal on his back and crossed the river. After the meal, the jackal laughed loudly and hid himself in the field. The farmer came running. He saw the camel eating sugar cane and gave him a good beating. The jackal laughed at the camel. Now the jackal and the camel had to cross the river again. When they reached the middle of the river, the camel took a dip into the water. The jackal fell into the water. He got a lesson for tricking his friend.

III. Complete the story by filling the words given below:

THE FOOLISH CROW

One day a crow found a piece of bread in a field. It picked up the bread and flew with it to a tree. It felt happy because the sun was shining and it had a whole piece of bread to eat.

A cunning fox came out of its den looking for something to eat. When it saw the crow with the bread, its mouth began to water. It decided to get the bread from the crow.

The fox greeted the crow and praised its voice. Then it asked the crow and sang a song. The foolish crow opened its mouth to sing. The bread fell down. The fox picked up the bread and ran away to its den, laughing all the way.

Write your favourite story in the given space.

Do it yourself.

21 Essay

Write an essay on :

(i) The Horse

1. A horse is a big and strong animal.
2. It has four legs, two ears, and a long tail
3. Horses can run very fast.
4. They eat grass, hay, and grains.
5. A horse lives in a stable.
6. People use horses for riding and carrying loads.
7. Horses are very helpful animals.
8. They come in many colors like black, brown, and white
9. A baby horse is called a foal.
10. I like horses because they are beautiful and fast.

(ii) Postman

1. A postman is a helpful person.
2. He brings letters and parcels to our homes.
3. He wears a uniform and carries a big bag
4. He travels by bicycle or on foot
5. He delivers letters every day
6. He works in all kinds of weather.

7. He gives us good news and messages
8. We should respect the postman
9. He is very hardworking and honest.
10. I like the postman because he helps everyone

(iii) Diwali

1. Diwali is a festival of lights.
2. It is a famous festival in India.
3. People clean and decorate their homes.
4. They light diyas and candles
5. People wear new clothes on this day.
6. We worship Goddess Lakshmi.
7. Children burst crackers and enjoy.
8. Families share sweets and gifts
9. It spreads happiness and joy everywhere.
10. I love Diwali very much.

(iv) My Mother

1. My mother is very kind and loving.
2. She takes care of our family.
3. She cooks tasty food for us.
4. She helps me with my homework
5. She wakes up early every day.
6. She teaches me good manners.
7. She loves me very much.
8. I also love my mother.
9. She is the best person in my life.
10. I am proud of my mother.

22 Paragraph Writing

Write a paragraph on the following topics. You may use the words given:

1. Sweet Home

My sweet home is a beautiful and peaceful place where I live with my family. It is

big and has many rooms. There is also a small garden where we grow flowers and play games. My family helps each other in every situation. We enjoy picnics and spend happy time together at home. Our house is full of love and care. I feel safe and comfortable in my home. I never want to leave it because it is the best place for me.

2. Cricket

Cricket is a very popular and beautiful game. It is played by players all over the world, especially in countries like England and India. There are two teams with batsmen and bowlers. The batsman scores runs while the bowler tries to take wickets. Cricket matches like the World Cup are very exciting. People love to watch and play cricket. It teaches teamwork and discipline. I enjoy playing cricket with my friends in the playground.

3. Holi

Holi is a famous festival of colours in India. It is celebrated with great joy and fun. People throw colours on each other and eat sweets. Friends and family visit each other and share happiness. Children especially enjoy playing with colours and water. Holi spreads love and removes differences between people. It is a festival of joy, unity, and friendship.

4. The Earth

The Earth is our home planet. It is round in shape and looks blue because of water. It has air, water, and land which support life. Many animals, trees, and humans live on Earth. There are mountains, rivers, and forests that make it beautiful. The Earth gives us everything we need to live. We must take care of it and keep it clean and safe.

A. Tick (✓) the right option :

1. A word used to name a person, animal, place or thing is called:

Ans. (i) a Noun

2. She dances well. The coloured word is:

Ans. (i) a Pronoun

3. Ashoka was a great ruler. The coloured word is:

Ans. (c) an Adjective

4. The baby cried. The coloured word is:

Ans. (a) a Verb

5. I go for morning walk regularly. The coloured word is:

Ans. (a) an Adverb

B. Match the Column 'A' and Column B. Draw lines from the part of speech to its example:

| 'A' | 'B' |
|-----------------|------------|
| 1. Noun | (d) river |
| 2. Pronoun | (g) he |
| 3. Adjective | (a) bridal |
| 4. Verb | (h) jump |
| 5. Adverb | (b) fastly |
| 6. Preposition | (e) on |
| 7. Conjunction | (c) or |
| 8. Interjection | (f) Alas! |

C. Read the following sentences and name the parts of speech of each coloured word :

1. The ship is in sight.

Preposition

2. Renu is coming tomorrow.

Adverb

3. Chandigarh is a beautiful city.

Noun

4. Time and tide wait for none.

Conjunction

5. The Ganga is a sacred river.

Verb

2

Nouns

A. Tick (✓) the right option:

1. River is a:

Ans. (i) common noun

2. House is a:

Ans. (i) common noun

3. There are _____ kinds of nouns.

Ans. (iii) four

4. A collection of sticks is called:

Ans. (iii) bundle

5. Gang, crowd and army are:

Ans. (ii) collective nouns

B. Each of the phrase given below contains a collective noun. Complete each phrase by using the missing words from the box below:

1. a heap of **stones**

2. a tuft of **grass**

3. a pack of **cigarettes**

4. a regiment of **army**

5. a fleet of **ships**

6. a herd of **cattle**

7. a bunch of **grapes**

8. a bouquet of **flowers**

C. Using the words given below fill in the blanks in the following sentences:

1. Get me a **tuft** of grass from the park.

2. His **keenness** for cricket is known to all.

3. What is the **length** of this piece of cloth?

4. A few **thefts** took place on the same night.

5. His **politeness** won him many friends.

6. What is the **height** of your son?

7. The naughty boy was given **treatment** for his act.

8. He is a member of the **board** of directors.

9. I had my **schooling** in Saraswati Public School.

10. Dr. Vinod's **speech** was correct.

D. Write the words given below under the headings common nouns and proper nouns:

| Proper Nouns | Common Nouns |
|--------------|--------------|
| India | teacher |
| Lal Qila | pen |
| Ganga | house |
| Sunday | nurse |
| January | month |
| Kolkata | park |
| Kamal | building |
| May | book |

E. Complete the following sentences choosing appropriate abstract nouns from the box:

1. **Happiness** is what everyone wants.
2. **Safety** first is a good motto.
3. **Cruelty** to animals must be stopped.
4. **Childhood** is the best period of one's life.
5. **Honesty** is a great virtue.
6. **Wastage** should always be avoided.
7. **Redness** in the eye is sometimes caused by dust and sand.

F. Answer the following questions:

1. Define proper noun.
A proper noun is the name of a particular person, place or thing and always begins with a capital letter.
2. What is common noun? Give some examples.
A common noun is a general name for persons, places or things of the same kind.
Examples: girl, book, river, animal.
3. Define collective noun.
A collective noun is the name of a group or collection of persons, animals or things taken together.
Examples: team, crowd, flock.
4. Define abstract noun.
An abstract noun is the name of something that we cannot see or touch but can only feel or think about.
Examples: love, honesty, bravery.

3

Nouns : Numbers

A. Tick (✓) the right option :

1. A noun that refers to one person or thing is called :

Ans. (ii) singular number

2. A noun that refers to more than one person or thing is called :

Ans. (i) plural number

B. Give the singular forms of :

- | | | | |
|-------------|--------------|-----------|--------------|
| 1. Keys | Key | 2. Wives | Wife |
| 3. Stories | Story | 4. Bushes | Bush |
| 5. Children | Child | 6. Chiefs | Chief |

C. Give the plural forms of :

- | | | | |
|----------|-------------|-----------|----------------|
| 1. Ox | Oxen | 2. Leaf | Leaves |
| 3. Mouse | Mice | 4. Monkey | Monkeys |
| 5. Deer | Deer | 6. Tooth | Teeth |

D. Fill in the blanks with suitable words :

1. My scissors **lie** on that table.
2. The mice **were** caught in the trap.
3. The oxen **were** found roaming in the field.
4. Mathematics **requires** hard work.
5. Her daughters in law **are** here.
6. The furniture **looks** quite new.

E. Answer the following questions.

1. Define singular number.

Ans. A singular number is a noun that refers to one person, animal, place or thing.

2. Define plural number .

Ans. A plural number is a noun that refers to more than one person, animal, place or thing.

4

Nouns : Gender

A. Tick (✓) the right option :

1. A noun that refers to a male is said to be of the :

Ans. (ii) masculine gender

2. A noun that refers to a female is said to be of the :

Ans. (i) feminine gender

B. Give the feminine of the following nouns :

- | | | | |
|--------------|--------------------|------------|-----------------|
| 1. Sir | Madam | 2. Waiter | Waitress |
| 3. Cock | Hen | 4. Father | Mother |
| 5. Uncle | Aunt | 6. Bull | Cow |
| 7. Nephew | Niece | 8. Duke | Duchess |
| 9. Washerman | Washerwoman | 10. Horse | Mare |
| 11. King | Queen | 12. Prince | Princess |

C. Write the masculine form of the following :

- | | | | |
|----------|-------------|------------|-------------------|
| 1. Queen | King | 2. Bride | Bridegroom |
| 3. Cow | Bull | 4. Lady | Gentleman |
| 5. Bitch | Dog | 6. Hostess | Host |
| 7. Hen | Cock | 8. Empress | Emperor |

D. Rewrite the following sentences using nouns and pronouns of the opposite gender :

1. The boy came first in the class.

Ans. The girl came first in the class.

2. The prince was very cordial.

Ans. The princess was very cordial.

3. The nephews and brothers came to see him.

Ans. The nieces and sisters came to see her.

4. The king is riding a horse .

Ans. The queen is riding a mare.

5. A widow is a woman who has lost her husband.

Ans. A widower is a man who has lost his wife.

6. Our nephew went to England.

Ans. Our niece went to England.

E. Answer the following questions :

1. Define masculine gender with example.

Ans. A noun that refers to a male is called masculine gender.

Example: boy, king, father

2. Define feminine gender with example.

Ans. A noun that refers to a female is called feminine gender.

Example: girl, queen, mother

5

Pronouns

A. Tick (✓) the right option :

1. Pronouns that stand for the name of people or thing, are called :

Ans. (i) Personal Pronouns

2. Pronouns that are used to ask question, are called :

Ans. (i) Interrogative Pronouns

B. Fill each blank with the proper form of a Reflexive Pronoun :

1. I myself solved the sum.
2. He write himself a novel.
3. Boy, you will hurt yourself.
4. I saw myself on TV last night.
5. The dog bit itself.
6. We did the work ourselves.

C. Fill in the blanks with Demonstrative Pronouns :

1. These are ripe mangoes; those are unripe.
2. These are my books; those are yours.
3. This is my car; that is yours.
4. These are vegetables and those are fruits.
5. This is my cat; that is yours.

D. Fill in the blanks with Interrogative Pronouns :

1. Which is this chair?
2. Whom do you want to meet?
3. Who is coming for the show?
4. Who is knocking at the door?
5. What is the matter?

E. Answer the following questions :

1. What are the kinds of pronouns?

Ans. Personal, Reflexive, Possessive, Demonstrative and Interrogative pronouns.

2. What are personal pronouns?

Ans. Pronouns that stand for the names of people or things are called personal pronouns.

3. What are reflexive pronouns?

Ans. Pronouns in which the action of the subject reflects upon the subject itself are called reflexive pronouns.

4. What are called interrogative pronouns?

Ans. Pronouns used to ask questions are called interrogative pronouns.

6

Adjectives

A. Tick (✓) the right option:

1. There are _____ kinds of adjectives.

Ans. (iii) six

2. Adjectives of number answers the question:

Ans. (iii) how many or in what order

B. Pick out the adjectives in the following sentences and write what kinds of adjectives they are :

- | | | |
|---|---------------|--------------------------------|
| 1. Please give me some water. | some | Adjective of Quantity |
| 2. Ripe mangoes are delicious. | ripe | Adjective of Quality |
| 3. There are seven days in a week. | seven | Adjective of Number |
| 4. He did not eat any food. | any | Adjective of Quantity |
| 5. Five boys were sitting in the room. | five | Adjective of Number |
| 6. Who gave you this book? | who | Interrogative Adjective |
| 7. Look at that bird. | that | Demonstrative Adjective |
| 8. There is little food in the kitchen. | little | Adjective of Quantity |

C. Match the following adjectives and nouns and write together :

- | | | |
|-----------------|--------------------|----------------------------|
| 1. thick | (f) forest | thick forest |
| 2. monthly | (e) rent | monthly rent |
| 3. beautiful | (b) doll | beautiful doll |
| 4. comfortable | (c) journey | comfortable journey |
| 5. satisfactory | (d) answer | satisfactory answer |
| 6. sour | (a) grapes | sour grapes |

D. Pick out with the adjectives in the following sentences :

- | | |
|--|-------------------|
| 1. The girl is happy to get a new pin. | happy, new |
| 2. She wears a red saree. | red |
| 3. Ashoka was a great ruler. | great |
| 4. Tagore was a great poet. | great |
| 5. There are twelve months in a year. | twelve |
| 6. I have enough work for today. | enough |
| 7. Vaibhav is a honest man. | honest |
| 8. My worker is very poor. | very poor |

E. Match the adjectives with the nouns they describe :

| A | B |
|------------|---------------|
| 1. fast | train |
| 2. clear | sky |
| 3. ripe | grapes |
| 4. open | door |
| 5. cunning | fox |
| 6. huge | whale |

F. Answer the following questions :

1. What is adjective?

Ans. An adjective is a describing word that tells us more about a person, place, animal, or thing.

2. Define adjective of number.

Ans. An adjective of number tells how many persons or things are meant or in what order.

3. Write two examples of interrogative adjective.

Ans. Which, What (you can also write: Whose)

4. Define adjective of quality.

Ans. An adjective of quality describes the quality of a person or thing.

7

Comparison of Adjectives

A. Tick (✓) the right option :

1. There are _____ Degrees of Comparison of Adjectives :

Ans. (ii) three

2. The simple form of the Adjective is called the :

Ans. (i) Positive Degree

3. The form of the Adjective used in comparing more than two objects is called the :

Ans. (iii) Superlative Degree

B. Fill in the blanks with the suitable Degrees of Adjectives given in the brackets :

1. Smita is the **best** dancer in her class.

2. Ekta has **many** friends.

8

Adverbs

A. Tick (✓) the right option :

1. A word which adds something to the meaning of a Verb is called :

Ans. (ii) Adverb

2. The Adverbs which tell us 'how an action is done, is being done or has been done, are called Adverbs of :

Ans. (i) Manner

3. Which of the following is an adverb?

Ans. (ii) Badly

B. Pick out the Adverbs in the following sentences and write in the given space :

- | | |
|------------------------------|--------------------|
| 1. The old man walks slowly. | slowly |
| 2. She writes beautifully. | beautifully |
| 3. The child spoke loudly. | loudly |
| 4. He is absolutely right. | absolutely |
| 5. The bird sings sweetly. | sweetly |
| 6. The glass is nearly full. | nearly |

C. Answer the following questions :

1. What are adverbs?

Ans. Adverbs are words that add something to the meaning of a verb. They tell us how, when, or where an action is done.

2. Give some examples of adverb.

Ans. **Examples:** slowly, quickly, beautifully, loudly, yesterday, here

9

Conjunctions

A. Tick (✓) the right option :

1. He worked hard _____ he failed.

Ans. (iii) but

2. Rahul _____ Tina are good friends.

Ans. (ii) and

3. It is very cold _____ I cannot go out.

Ans. (i) therefore

B. Underline the conjunction in each sentence and rewrite :

- | | |
|--|----------------|
| 1. When the rain stopped, we started our journey. | when |
| 2. The mice are sure to play when the cat is away. | when |
| 3. My brother is at home because I am sick. | because |
| 4. Mumbai is larger than Meerut. | than |
| 5. Wait here till the teacher returns. | till |

C. Use (and, but, or) to join each pair of sentences into one :

1. You can go to Shimla by road. You can go by air.3

Ans. You can go to Shimla by road or by air.

2. Somesh went to fair. Sagar went to see a movie.

Ans. Somesh went to fair and Sagar went to see a movie.

3. I take tea. You take milk.

Ans. I take tea but you take milk.

4. Riya is playing. Aaditya is doing his homework.

Ans. Riya is playing and Aaditya is doing his homework.

5. You may take this book. You may leave it.

Ans. You may take this book or leave it.

D. Make correct pairs from the words given in the box below. One is done for you:

- | | |
|---------------------|-------------------|
| 1. bread and butter | 2. cup and saucer |
| 3. day and night | 4. hot and cold |
| 5. short and long | 6. old and young |

E. Answer the following questions :

1. Write the definition of conjunction.

Ans. Conjunctions are joining words. They join words, groups of words or sentences.

2. Write some words of conjunctions.

Ans. and, but, or, because, when, so, therefore, till, before, after

10 Prepositions

A. Tick (✓) the right option :

1. A word which shows the position of things, is called :

(i) Conjunction

2. He deals _____ sugar.

(ii) in

B. Fill in the blanks with suitable Prepositions :

1. She is sure **of** success.
2. There is a fence **around** the field.
3. The sky is **over** our heads.
4. He invited me **to** lunch.
5. Don't walk **behind** me.
6. The boy saw a snake **at** his foot.
7. Come **into** the classroom.
8. Father is **at** home.
9. Smoking is injurious **to** health.
10. We took shelter **under** a tree.
11. He is fond **of** skating.
12. The ball is **in** the well.



C. Make your own sentences using the following Prepositions :

- | | |
|----------------|--|
| 1. into | The boy jumped into the well. |
| 2. on | They will come on Sunday. |
| 3. among | The teacher is among the children. |
| 4. through | The train passed through the tunnel. |
| 5. beside | Sit beside me. |
| 6. from | She is coming from Delhi. |
| 7. in front of | There is a garden in front of my house. |

D. Answer the following questions :

1. What is the use of Prepositions?

Ans. Prepositions are used to show the relationship between nouns or pronouns and other words in a sentence.

2. Define Prepositions.

Ans. Prepositions are words that show the relation between the person or thing denoted by the noun and something else in the sentence.

11 Interjections

A. Tick (✓) the right option :

1. An Interjection is a word which express some sudden :

Ans. (iii) feelings.

2. _____ ! the baby is sleeping.

Ans. (ii) Hush

B. Write the correct Interjection:

1. Hello! I'm Bunny speaking.
2. Hey! Listen to me, you boys.
3. Ouch! The thorn is giving me too much pain.

C. Underline the Interjection in the following sentences:

1. Alas! My friend has met with an accident.
2. Where are you going?
3. Oh! We have got too much work to do.
4. Bravo! You did very well in the test.
5. Hurrah! We have got new furniture.
6. What! Have I to stay here all alone?
7. Hush! The teacher is speaking.
8. How beautiful flower is!

D. Complete the sentences using the correct Interjections:

1. **Hurrah**! How happy they seem.
2. **Alas**! My sister is in the hospital.
3. **Wow**! My father has become the city Mayor.
4. **Alas**! Your story is really very sad.
5. **Bravo**! You really played very well.
6. **Hush**! The baby is sleeping.
7. **Hello**! How are you?
8. **Bravo**! You have done well.

E. Re-write the following sentences using exclamation marks at the correct places:

1. How beautiful is the rainbow.

Ans. How beautiful is the rainbow!

2. May you live long.

Ans. May you live long!

3. Good Heavens.

Ans. Good Heavens!

4. Bravo well done.

Ans. Bravo! Well done!

F. Answer the following questions:

1. What is Interjection?

Ans. An interjection is a word that expresses sudden feelings or emotions.

2. Give some examples of Interjection?

Ans. **Examples:** Hurrah, Alas, Oh, Hello, Bravo, Hush, Wow, Ouch

12 Verbs : Action Words

A. Tick (✓) the right option :

1. A _____ denotes an action or being or possession.

Ans. (ii) Verb

2. _____ Verb require an object to complete into meaning.

Ans. (i) Transitive

B. Fill in each blank with the correct verb from those given in the box:

- The birds fly in groups.
- An eagle flies very fast.
- The sun gives us light and heat.
- The blind man moves slowly.
- Dogs bark at strangers.
- The moon shines at night.
- I always get my news from the 'Hindu'.
- I live happily here.
- Why do you look at me like this?
- Two and three make five.

C. Below are given some nouns and their action words. Put the correct action word against the nouns:

- | | | | |
|-------------|---------------|---------------|--------------|
| 1. Ears | hear | 2. The kettle | boils |
| 3. Eyes | see | 4. The wind | blows |
| 5. The nose | smells | 6. Peacocks | dance |
| 7. Teeth | bite | 8. Aeroplanes | fly |
| 9. Ships | sail | 10. Pens | write |

D. Draw a line to match the animals with their sound:

- | | |
|----------|---------------|
| 1. Goats | Bleat |
| 2. Deer | Bell |
| 3. Mice | Squeak |
| 4. Crows | Caw |

- | | | |
|----|-----------|----------------|
| 5. | Horses | Neigh |
| 6. | Elephants | Trumpet |
| 7. | Cows | Moo |
| 8. | Donkeys | Bray |

E. Now fill in the blanks in each sentence with 'is, am, are, was or were'.

1. I was ill yesterday.
2. I am going to temple.
3. They are present now.
4. They were absent in the morning.
5. The days are hot in June.
6. They are cold in December.
7. The man sitting on road is a beggar.
8. The girls are watching the TV now.
9. There were many passengers in the train yesterday.
10. It is a difficult question.
11. Smita is a good girl.
12. Smita and Jaya are good girls.
13. The parents were quite angry in the last PTA meeting.
14. We are going to Shimal tomorrow.
15. He is crying now.

13

Verbs : Tenses

A. Tick (✓) the right option:

1. The 'Verb' tell us about the _____ when an action takes place.

Ans. (iii) time

2. Words that tell us about actions that are still happening are said to be in the:

Ans. (iii) Present Continuous Tense

B. Fill in the blanks with Present Continuous form of the verbs given in the brackets :

1. I **am writing** a letter.
2. She **is driving** a car.
3. The train **is leaving** the platform.

4. They **are watching** the TV now.
5. The baby **is sleeping** peacefully in the cradle.
6. Who **is sitting** on my chair?

C. Fill in the blanks with Past Continuous form of the verbs given in the brackets :

1. Children **were flying** kites in the park.
2. Jackals **were howling** in the fields at night.
3. The lark **was soaring** high in the sky.
4. The dogs **were barking** at the poor beggar.
5. The stars **were twinkling** in the clear night sky.
6. The constable **was chasing** the thief hotly.

D. Fill in the blanks with Future Continuous form of the verbs given in the brackets:

1. Mohit **will be laughing**.
2. I **shall be jumping**.
3. The sweeper **will be sweeping**.
4. The girls **will be watching** TV.
5. The sun **will be rising** very soon.
6. The children **will be sleeping** when we get home.
7. I **shall be needing** these books tomorrow.

14

Articles : A, An and The

A. Tick (✓) the right option and fill in the blanks:

1. There are _____ articles.

Ans. (i) two

2. Kamal bought _____ car.

Ans. (i) a

3. He is _____ honest man.

Ans. (ii) an

4. Mr. Sharma is _____ best teacher.

Ans. (i) the

B. Fill in the blanks with a or an:

- | | |
|---------------------|----------------------|
| 1. an hour. | 2. a chair. |
| 3. an apple. | 4. an inkpot. |

- | | |
|------------------------------|--------------------------|
| 5. an unhappy person. | 6. a brave man. |
| 7. a shirt. | 8. an honest man. |
| 9. an egg. | 10. a loud voice. |

C. Fill in blanks with a, an or the as required:

1. Wisdom is **a** great virtue.
2. He is **an** honest man.
3. Sunita is **a** good girl.
4. English is not **a** easy language.
5. There are seven days in **a** week.
6. We went to see **the** Taj Mahal.
7. **The** Red Fort was built by Shah Jahan.
8. God made **the** sun and **the** moon.
9. Tanu borrowed **a** pencil from Riya.
10. Tanu bought **a** box full of toffees.
11. I did not enjoy **the** book she gave me.
12. What is **the** time?

D. Answer the following questions:

1. What are the types of articles?

Ans. There are two types of articles:

- Definite article (The)
- Indefinite articles (A, An)

2. Define vowels.

Ans. Vowels are the letters: a, e, i, o, u.

3. Define consonants.

Ans. All letters of the alphabet except vowels are called consonants.

15 Articles : A, An and The

A. Tick (✓) the right option

1. Full stop is used _____ of a sentence.

Ans. (ii) in the end of

2. The first word of a sentence begins with _____.

Ans. (ii) a capital letter

B. Supply all the necessary Stops and Capital Letters in the following sentences :

1. sachin met me at the station last sunday

Ans. Sachin met me at the station last Sunday.

2. i met priya at the party.

Ans. I met Priya at the party.

3. lion tiger and leopard all belong to the cat family

Ans. Lion, tiger and leopard all belong to the cat family.

4. maharana pratap was a great king

Ans. Maharana Pratap was a great king.

5. delhi is the capital of india

Ans. Delhi is the capital of India.

6. where has kamal gone

Ans. Where has Kamal gone?

7. lord rama killed the demon king ravana

Ans. Lord Rama killed the demon king Ravana.

8. the taj mahal in india was built hundreds of year ago

Ans. The Taj Mahal in India was built hundreds of years ago.

C. Answer the following questions :

1. What is the meaning of punctuation?

Ans. Punctuation means putting pauses at the right places in sentences to express the meaning clearly and to make it easier to understand.

2. What is the use of questions mark?

Ans. The Question Mark is placed at the end of an interrogative sentence (a sentence that asks a question)

3. Define the mark of exclamation.

Ans. The Mark of Exclamation is used after an exclamatory word (like Bravo! or Hurrah!) and an exclamatory sentence to express strong feelings.

16 The Sentences

A. Tick (✓) the right option :

1. A sentence makes _____ sense.

Ans. (ii) complete

2. A sentence begins with a :

Ans. (iii) capital letter

3. An assertive sentence _____ or _____ something.

Ans. (iii) both of these

4. An _____ sentence asks a question.

Ans. (i) interrogative

5. In a sentence the person, the thing or the animal we speak about, is called the :

Ans. (iii) subject

6. What is said about the subject is called :

Ans. (ii) predicate

B. Match the following to make meaningful sentence:

- | | |
|------------------------|---|
| 1. The mariners heard | c. a warning bell |
| 2. A painting was hung | d. in the hall |
| 3. The knight fought | b. in a brave manner |
| 4. The sultan is a man | e. of wealth |
| 5. The flowers | a. in the garden are very pretty |

C. Write whether the sentences are assertive, interrogative, imperative or exclamatory against each sentence:

- | | |
|---------------------------------------|----------------------|
| 1. What a fine scene ! | Exclamatory |
| 2. Take light meal. | Imperative |
| 3. When do you go to school? | Interrogative |
| 4. My father gave me a pen. | Assertive |
| 5. How beautiful the building looks ! | Exclamatory |
| 6. O' for the wings of a bird ! | Exclamatory |
| 7. He is very clever boy. | Assertive |
| 8. This place is not clean. | Assertive |

D. Divide the following sentences into subject and predicate :

- | | Subject | Predicate |
|---|---------------------|--------------------------------|
| 1. The wind is blowing. | The wind | is blowing |
| 2. Delhi is the capital of India. | Delhi | is the capital of India |
| 3. She worked hard. | She | worked hard |
| 4. The gardener is watering the plants. | The gardener | is watering the plants |
| 5. My father is a teacher. | My father | is a teacher |
| 6. This flower smells sweet. | This flower | smells sweet |

E. Answer the following questions :

1. Define sentence.

Ans. A sentence is a group of words arranged in such a way that it makes complete sense.

2. What is interrogative sentence?

Ans. An interrogative sentence is a sentence that asks a question.

3. What is imperative sentence?

Ans. An imperative sentence gives a command, request, or advice.

17

Prefixes and Suffixes

A. Tick (✓) the right option :

1. Prefixes are placed at the _____ of the word .

Ans. (ii) beginning

2. In misbehave, prefix is :

Ans. (iii) mis

3. Suffix is placed at the _____ of the word.

Ans. (ii) end

4. Suffix are used to form

Ans. (iii) both of these

B. Given below are some prefixes. Place them correctly before the given words to get new words:

- | | | | |
|--------------|--------------------|--------------|-------------------|
| 1. secure | insecure | 2. like | dislike |
| 3. obedient | unripe | 4. ripe | unripe |
| 5. happy | unhappy | 6. regular | irregular |
| 7. ability | inability | 8. take | intake |
| 9. religious | irreligious | 10. possible | impossible |
| 11. agree | disagree | 12. proper | improper |

C. Fill in the blanks with the words derived from the ones given in the brackets. Remember to use the right prefixes:

- Kamal's teacher were **satisfied** with his progress in his studies.
- Aanya's **polite** and **courteous** behaviour towards the guests was praised by all.
- Don't be **unkind** and cruel to animals.
- Diya behaved in a very **responsible** and **mature** manner.

D. Form new words from the following, using suffixes:

1. -ness, -er or r:

- | | | | |
|-----------|------------------|-----------|------------------|
| (a) shrap | sharpness | (b) tight | tightness |
| (c) tall | taller | (d) write | writer |

2. -ful or -less:

- | | | | |
|----------|-----------------|------------|------------------|
| (a) harm | harmful | (b) wonder | wonderful |
| (c) rest | restless | (d) home | homeless |

3. -ion:

- | | | | |
|---------------|--------------------|-------------|-------------------|
| (a) narrate | narration | (b) correct | correction |
| (c) celebrate | celebration | (d) operate | operation |

E. Fill in the blanks with the words derived from the ones given in the brackets. Use the correct suffix:

1. The **election** of the secretary of the society will take place next week. (elect)
2. Virat Kohli is my favourite **cricketer**. (cricket)
3. He is very **hopeful** of getting a better paid job. (hope)
4. Her eyes had **hardly** closed when the telephone rang. (hard)
5. We went to the **bakery** nearby to order a birthday cake. (bake)

F. Fill in the blanks with the correct form of the word given in the brackets. Remember to add a prefix or suffix:

1. It was **nearly** dark when we returned home from the party.
2. All of us nodded in **agreement** to father's decision. (agree)
3. He asked us to his house which was very small and **untidy**.

G. Answer the following question:

1. Define prefix.

Ans. A prefix is a letter or a group of letters added at the beginning of a word to change its meaning or form a new word.

2. Define suffix.

Ans. A suffix is a letter or a group of letters added at the end of a word to change its meaning or form a new word.

18 Vocabulary

A. Fill the synonym of the word written in brackets:

1. Do not **allow** this girl to enter the class.
2. Plants slowly **increase** in size.
3. Do you get up **soon** in the morning.
4. Weather was **pleasant** at Shimla.
5. We must **feed** our pet animals.
6. I pay monthly **rent** to my house.
7. The **empire** of Ashoka the Great was the first kingdom.
8. Akshay Kumar is a popular **star**.
9. Be **nice** to your friends.
10. Always **obey** your elders.

B. Write the antonym of the following words :

Beautiful **Ugly**

Victory **Defeat**

Broad **Narrow**

Care **Neglect**

| | | | |
|------|------------------|--------|----------------|
| End | Start | Famous | Unknown |
| Kind | Unkind | Get | Lose |
| Nice | Rude | Love | Hate |
| Ugly | Beautiful | Rise | Fall |

C. Who are they? Choose your answers from the box and write in the blank lines:

- | | |
|--|--------------------|
| 1. A person who flies aeroplanes | Pilot |
| 2. A person who drives vehicles | Driver |
| 3. A person who builds houses with stones | Mason |
| 4. A person who delivers letters | Postman |
| 5. A person who makes and repairs shoes | Cobbler |
| 6. A person who sells things | Vendor |
| 7. A person who sells flowers | Florist |
| 8. A persons who sells fruits and vegetables | Greengrocer |

19 Application Writing

A. Write an application to the Principal for four days leave as you are suffering from small pox.

To

The Principal

Ferry Academy

Punjabi bagh, Saharanpur

Respected Madam,

Kindly grant me leave for four days as I am suffering from smallpox. The doctor has advised me to take complete rest.

I shall be very thankful to you.

Yours obediently

Kamal Garg

Date : _____

B. Write an application to the Principal for picnic.

To

The Principal

J. M.J. College

Meerut

Respected Madam,

I request you to kindly grant permission for a class picnic. We want to go on a picnic with our classmates. It will be very enjoyable and helpful for us. Kindly allow us to go for the picnic.

Yours obediently

Riya

Date : _____

C. Write an application to the Principal for changing the class section.

To

The Principal

D.N. Public School

Delhi

Respected Madam,

I request you to kindly change my class section. I want to move to another section because my elder brother/sister studies in that section.

Kindly consider my request.

Yours obediently

Aman

Date : _____

D. Write an application to the Principal for fee concession.

To

The Principal

Khalsa Public School

Saharanpur

Respected Madam,

I request you to kindly grant me fee concession. My father's income is very low and he is unable to pay my school fees.

Kindly help me by giving fee concession.

Yours obediently

Rohan

Date : _____

20 Letter Writing

A. Fill in the blanks given in the help box :

Address : 12, Green Park

Delhi

Date : 15 July

My dear friend,

I congratulate you on your 10th birthday on 15th July. I wish you a very bright future ahead. Please accept this small gift on your birthday.

Your loving friend,

Shalini.

B. Write a letter your mother to know news of your family members.

Jorge Street, Shimla

18th May 20xx

My dear Mother,

I am fine here and hope you are also fine there. I am writing this letter to tell you about our family. Father is doing well in his work. Brother is studying hard for his exams. Everyone at home is happy and healthy. I miss you very much. Please take care of yourself.

Your loving son,

Raj

C. Write a letter to your father for informing him that you have got free scholarship.

45, School Hostel

Lucknow

5th September 20xx

My dear Father,

I am fine here and hope you are also fine. I am very happy to tell you that I have got a free scholarship in my school because of my good performance in studies. This will help in my education and reduce your burden. I will continue to work hard.

Your loving son,

Rahul

D. Write a letter to your sister congratulating her for getting first position in the examination.

23, Nehru Nagar

Mumbai

20th March 20xx

My dear Sister,

I am very happy to hear that you have got first position in your examination. Congratulations on your great success! You have made all of us proud. Keep working hard and achieve more success in life.

With lots of love,

Your loving brother,

Vishal

21 Comprehension

1. COMPREHENSION

Answer the following questions :

1. Where do the penguins live ?

Ans. Penguins live in Antarctica and off the coasts of Africa and Australia.

2. What is the smallest penguin called ?

Ans. The smallest penguin is called the Blue Fairy.

3. How tall is the smallest penguin ?

Ans. The smallest penguin is about 40 cm tall.

4. What do the penguin eat ?

Ans. Penguins eat fish.

5. Whose prey are the penguins ?

Ans. Penguins are the prey of leopards, seals, and killer whales.

2. COMPREHENSION

Answer the following questions :

1. Where did the fox live ?

Ans. The fox lived in a forest.

2. Why did the fox wander in the forest ?
Ans. The fox wandered in search of food because she was hungry.
3. What did she decide at last ?
Ans. She decided to go back home.
4. What did she see ?
Ans. She saw bunches of grapes.
5. What did she do to eat the grapes ?
Ans. She jumped up to reach the grapes.
6. What did she say ?
Ans. She said, "I shall not eat these grapes because they are sour."

3. COMPREHENSION

Answer the following questions :

1. Who was reborn as a mouse?
Ans. A rich merchant's wife was reborn as a mouse.
2. What did the mouse request the stonecutter to buy?
Ans. The mouse requested him to buy some meat.
3. How did the mouse save life from the cat?
Ans. She saved her life by promising the cat a portion of her daily food.
4. What did the cat do when the mouse refuse her for giving food?
Ans. The cat jumped into the crystal box and was pierced to death.

4. COMPREHENSION

Answer the following questions :

1. Who went to a jungle for a picnic?
Ans. A few townsmen went to the jungle for a picnic.
2. Who said, "Make the fire ready. I will get some fresh meat for all us."
Ans. One of the townsmen said this.
3. Where did the man go?
Ans. He went to a nearby lake.
4. What did he do near the lake?
Ans. He lay down pretending to be dead.

5. How did the wolf save his life?

Ans.

The wolf stayed alert, suspected a trick, and ran away quickly, thus saving his life.

22 Comprehension

Note: This chapter is only for reading and practice.

A. Tick (✓) the right option:

1. A group of words that makes complete sense is called:

Ans. (ii) a sentence

2. Which of the following is the mark of exclamation?

Ans. (i) !

3. An _____ sentence can give an order or make a request.

Ans. (iii) imperative

B. Write the following sentence in correct order:

1. help poor always people.

Ans. Always help poor people.

2. was great a king Ashoka.

Ans. Ashoka was a great king.

3. your mother is where?

Ans. Where is your mother?

4. the man old slowly speaks.

Ans. The old man speaks slowly.

C. The words have been jumbled. Put them in their right order so that they make sentences:

1. east, in, sun, the, rises, the

Ans. The sun rises in the east.

2. the, is, india, delhi, capital, of

Ans. Delhi is the capital of India.

3. a, girl, is, Ekta, good

Ans. Ekta is a good girl.

4. without, air, cannot, live, we

Ans. We cannot live without air.

5. she, to, eat, loves, mango

Ans. She loves to eat mango.

D. Punctuate the following sentences and identify the types of sentences as statement (S), command (C), request (R) or exclamatory (E):

1. when will you go to mumbai
Ans. When will you go to Mumbai? **Interrogative**
2. oh no i've lost my watch
Ans. Oh no! I've lost my watch! **E**
3. i am going to picnic
Ans. I am going to picnic. **S**
4. do not write anything on this wall
Ans. Do not write anything on this wall. **C**
5. please give me your pen
Ans. Please give me your pen. **R**
6. humpty dumpty sat on a wall
Ans. Humpty Dumpty sat on a wall. **S**
7. she loves to eat mango
Ans. She loves to eat mango. **S**

E. Answer the following questions:

1. Define sentence.
Ans. A sentence is a group of words that makes complete sense.
2. What are interrogative sentences?
Ans. Interrogative sentences are sentences that ask questions.
3. What are exclamatory sentences?
Ans. Exclamatory sentences express strong or sudden feelings.
4. What are imperative sentences?
Ans. Imperative sentences give orders or make requests.



2

Subject and Predicate

A. Tick (✓) the right option :

1. Brush your teeth daily.
 The hidden subject in the sentence is _____.
- Ans.** (a) you
2. All the sentences have _____.
- Ans.** (c) both (a) and (b)

B. Draw a line to join the subject and predicate.

1.  The peacock (f) is our national bird
2.  Tricolour (h) is our national flag
3.  The trees (a) give us shade
4.  The earth (b) evolves around the sun
5.  My father (g) is a teacher
6.  The fire (c) gives us heat
7.  Mango (d) is a delicious fruit
8.  Lala Lajpat Rai (i) was a great leader
9.  Fresh fruit (j) keeps the doctor away
10.  Tiger (e) lives in the forest

C. Write suitable predicate for the subjects given below :

1. The Himalayas are very high mountains.
2. A year has twelve months.

- | | | |
|-----|----------------|---------------------|
| 3. | My grandfather | tells me stories. |
| 4. | The poem | is very beautiful. |
| 5. | Factories | produce goods. |
| 6. | Our library | has many books. |
| 7. | The forest | is very dense. |
| 8. | Many of us | like to play games. |
| 9. | The Ramayana | is a holy book. |
| 10. | My doll | is very pretty. |

D. Write suitable subjects for the predicates given below :

- Delhi** is the capital of India.
- Dictionary** gives the meaning of words.
- Children** are usually afraid of lightning.
- India** is our country.
- Girls** like to play with dolls.
- The sun** shines in the sky.
- The shopkeeper** has no sugar to sell.
- Rabbits** are fond of eating carrots.
- Ramesh** is my best friend.
- Yesterday** was very hot.

E. Answer the following question :

- What is subject?

Ans. The subject is the part of a sentence that tells us what or whom the sentence is about.

- Define predicate?

Ans. The predicate is the part of a sentence that tells us something about the subject.

3

Nouns

A. Tick (✓) the right option :

- A noun is the name of a :

Ans. (iii) both of these

- A _____ is the name of a particular person, place, animal or thing.

Ans. (iii) proper noun

3. Nouns that name a collection of things or people are called :

Ans. (i) collective nouns

4. All things, people, animals, etc. that we can see and touch are _____.

Ans. (ii) concrete nouns

5. An _____ is the name of some quality, state, action, idea, feeling etc. which we can only think of or feel but cannot touch.

Ans. (i) abstract nouns

B. In the following sentences, underline the common nouns, circle the proper nouns and put a double line under the collective nouns:

1. (Sagar) went to the theatre to watch a movie, but came away because of the crowd.
2. (Sandhya) saw a flock of birds in the sky.
3. (Shubman Gill) is the captain of the (Indian Cricket Team).
4. (Mozart) was a great musician and composed many beautiful pieces.
5. (Louis Pasteur) spent hours in his laboratory trying to invent new things.

C. Fill in the blanks with the abstract form of the words given in the brackets :

1. Kashmir is known for its natural beauty.
2. Horse are known for their loyalty and faithfulness to their masters.
3. poverty and corruption should be completely removed.
4. Tenali Rama was known for his wisdom.
5. Animals should be treated with love and kindness.

D. Fill in the blanks using the kind of nouns mentioned in the brackets:

1. Every Sunday, the preacher explained the Bible to the congregation .
2. Gandhi ji always spoke the truth .
3. The people of India are proud of the soldiers fighting for their country.
4. The box had a brass lock that could not be unlocked.

E. Answer the following questions :

1. What is common noun? Give examples .

Ans. A common noun is the name of a general person, place, animal or thing.

Examples: boy, city, book, dog

2. What is collective noun? Give examples .

Ans. A collective noun is the name of a group of people, animals or things.

Examples: team, flock, crowd, bunch

3. What do you understand by countable and uncountable nouns?

Ans.

Countable nouns: Things that can be counted (books, apples).

Uncountable nouns: Things that cannot be counted (milk, water).

4. Write some examples of abstract noun.

Ans.

honesty, kindness, beauty, anger, happiness

4

Pronouns and Their Kinds

A. Tick (✓) the right option :

1. A word which is used instead of a Noun, is called :
(iii) Pronoun
2. Personal Pronouns stand for the _____ persons.
(ii) three
3. Reflexive Pronouns behave like objects to the :
(i) Verb

B. Fill in the blanks with Relative Pronouns :

1. Is this the road **which** leads to the station ?
2. Where is the pen **that** you bought last sunday ?
3. I have found the book **that** I lost ?
4. The idea **that** you gave me is excellent.
5. God helps those **who** help themselves.
6. The girl **who** stood first is my cousin.

C. Fill in the blanks with Interrogative Pronouns :

1. **Who** has come to meet me.
2. **Whom** were you speaking to ?
3. **What** is the matter ?
4. **What** is the news ?
5. **Whose** your book?
6. **What** is that ?
7. **What** is there ?
8. **Whom** do you want to meet?

D. Fill in the blanks with suitable Possessive Pronouns:

1. I own that bike; that bike is **mine**
2. We own that puppy; it is **ours**
3. They own that car; that car is **theirs**
4. You own that cycle; that cycle is **yours**
5. She owns that scooty; that scooty is **hers**

E. Join each pair of sentences into one sentence using the given Relative Pronouns :

1. The captain praised Virat. Virat's batting was very good.

Ans. The captain praised Virat **whose** batting was very good.

2. The boy is watching TV. He is my brother.

Ans. The boy **who** is watching TV is my brother.

3. The pictures are very beautiful. They are on the wall.

Ans. The pictures **which** are on the wall are very beautiful.

4. The boy tells lies. He deserves to be punished.

Ans. The boy **who** tells lies deserves to be punished.

F. Underline the Pronouns in the following sentences and write which are Emphasizing and which are Reflexive:

1. I blame myself for it. **Reflexive**
2. I posted the letter myself. **Emphasizing**
3. They hid themselves. **Reflexive**
4. The officer herself gave the prize. **Emphasizing**
5. He poisoned himself. **Reflexive**
6. I myself solved the problems. **Emphasizing**
7. They hurt themselves during the game. **themselves**

G. Change some of the Nouns into Pronouns in the following sentences:

1. Proteins are needed for the growth of the body. Proteins also help the body to replace dead cells.

Proteins are needed for the growth of the body. **They** also help the body to replace dead cells.

2. Megha and Priya are neighbours. Megha and Priya study in the same class.

Megha and Priya are neighbours. **They** study in the same class.

3. A girl saw a painting. The girl wanted the painting. The girl said, "The painting is nice." The girl took the painting.

Ans. A girl saw a painting. **She** wanted it. **She** said, "It is nice." **She** took it.

H. Answer the following questions :

1. What are the three persons of Personal Pronoun?

- Ans.**
- First Person (I, we)
 - Second Person (you)
 - Third Person (he, she, it, they)

2. What is the difference between Reflexive Pronoun and Emphasizing Pronoun?

Ans. Reflexive Pronouns show that the action of the subject reflects back on itself. Emphasizing Pronouns are used to give emphasis to the subject.

3. What are Demonstrative Pronouns?

Ans. Demonstrative Pronouns are pronouns used to point out specific objects.
(this, that, these, those)

4. What do you understand by Interrogative Pronouns?

Ans. Interrogative Pronouns are used to ask questions.
(who, whom, what, which, whose)

5

Gender

A. Tell the correct gender of the words in colour. Write (M) for masculine; (F) for feminine; (C) for common and (N) for neuter in the circle(s) against each sentence.

1. Don't make friends with bad boys.
friends (C), boys (M)
2. A thing of beauty is a joy for ever.
thing (N), beauty (N)
3. Some people still believe in witches and ghosts.
people (C), witches (F), ghosts (N)
4. A girl is dancing.
girl (F)
5. The child is cutting its nail.
child (C), its (N)

6. She is his friend.
she (F), friend (C)
7. What a pretty dress!
dress (N)
8. Who is the owner of this car?
owner (C), car (N)
9. His aunt gave him a gift.
aunt (F), him (M)
10. The bride looked beautiful.
bride (F)

B. Rewrite the following sentences changing the gender of the nouns and pronouns:

1. The boy came first in the class.

Ans. The **girl** came first in the class. _____

2. Our nephew went to Mumbai.

Ans. Our **niece** went to Mumbai.

3. The milkmaid gave us milk.

Ans. The **milkman** gave us milk.

4. The tiger carried away the daughter of a villager.

Ans. The **tigress** carried away the son of a villager.

5. This actor always plays the part of a king in the films.

Ans. This **actress** always plays the part of a queen in the films.

6. The princess is very beautiful.

Ans. The **prince** is very handsome.

7. The kind princess took the poor lady to her palace.

Ans. The kind **prince** took the poor man to his palace.

8. The old man felt the loss of his wife.

Ans. The old **woman** felt the loss of her husband.

C. Answer the following questions :

1. Define gender.

Ans. Gender tells us whether a noun or pronoun is male, female, common, or neuter (without life).

2. What is common gender? Give examples.

Ans. Common gender refers to nouns that can be used for both male and female.
Examples: friend, student, teacher

3. What is neuter gender? Give examples.

Ans. Neuter gender refers to nouns that have no life (non-living things).
Examples: table, chair, pen

6

Numbers

A. Tick (✓) the right option :

1. Plural form of month is _____ .

Ans. (ii) months

2. Plural form of mouse is _____ .

Ans. (ii) mice

3. Singular form of women is _____ .

Ans. (iii) woman

B. Write the singular of the following nouns:

- | | | | |
|-----------|--------------|-------------|--------------|
| 1. feet | foot | 2. children | child |
| 3. weeks | week | 4. plates | plate |
| 5. ponies | pony | 6. wives | wife |
| 7. flies | fly | 8. sheep | sheep |
| 9. geese | goose | 10. fishes | fish |

C. Rewrite these sentences in the singular form:

- | | |
|---------------------------------------|--|
| 1. There were no boats. | There was no boat. |
| 2. No buses were running on the road. | No bus was running on the road. |
| 3. The cats are under the table. | The cat is under the table. |
| 4. These women are fashionable. | This woman is fashionable. |
| 5. These doors are very strong. | This door is very strong. |

D. Give the opposite number of the following nouns:

| | | | | | |
|---------|----------------|---------|----------------|--------|----------------|
| mango | mangoes | cargo | cargoes | deer | deer |
| flies | fly | goose | geese | leaves | leaf |
| foot | feet | news | news | houses | house |
| fish | fish | shop | shops | cuckoo | cuckoos |
| negroes | negro | mice | mouse | enemy | enemies |
| media | medium | classes | class | women | woman |

E. Fill in the blanks with the correct verb from those given in the brackets against each sentence:

- Priya is my friend.
- The boys over there are my friends. (is, are)
- Politics is a dirty game. (are, is)

F. Answer the following questions :

1. Define singular.

Singular is a noun or pronoun that refers to one person, place, animal, or thing.

2. Define plural.

Plural is a noun or pronoun that refers to more than one person, place, animal, or thing.

7

Adjectives

A. Tick (✓) the right option:

1. _____ is a word used to add something to the meaning of a noun or a pronoun.

(iii) An adjective

2. These, that, this, those and such are _____ adjectives.

(i) demonstrative

3. Adjectives of quality have _____ degrees of comparisons.

(ii) three

4. Comparative degree of hard is _____ .

(i) harder

5. Superlative degree of 'bad' is _____ .

(i) worst

B. Fill in the blanks with the correct form of the adjectives given in the brackets:

1. A lion is **stronger** than a wolf.
2. This is the **most interesting** story I have ever read.
3. Mahatma Gandhi was the **greatest** of all the leaders.
4. Of these two books, this one is **simpler**.
5. Mohan is the **oldest** boy of our class.
6. She is not so **rich** as he.
7. The pen is **mightier** than the sword.
8. Juhi is **better** than Madhuri.
9. Kolkata is the **largest** city of India.
10. The giraffe has a **long** neck.

C. Underline the adjectives in these sentences and state their kind:

1. Haridwar is a holy city. Adjective of Quality
2. That child always comes late. Demonstrative Adjective
3. Always drink pure water. Adjective of Quality
4. This is such a beautiful painting. such = Demonstrative, beautiful = Quality
5. Riya has four pencils. Adjective of Number

D. Underline the adjectives and say what kind of adjective each one is by writing in the space provided:

1. There were twenty boys in the class. Adjective of Number
2. Shaan is a lazy boy. Adjective of Quality
3. There is a little milk in the pot. Adjective of Quantity
4. Who is your brother? Possessive Adjective
5. I do not like those books. Demonstrative Adjective

8

Adverbs

A. Tick (✓) the right option:

1. The adverb which shows how an action is done, called:

Ans. (i) Adverb of manner

2. Adverbs of time shows _____ the action is done.

Ans. (iii) when

3. Interrogative adverbs are used to _____ questions.

Ans. (iii) ask

B. Pick out the adverbs in the following sentences by underlining them and then tell what kind of adverb is each by writing in the space provided:

1. Walk forward and then walk slowly. Adverb of place, Adverb of manner

- | | |
|---|--|
| 2. She wrote her exercise <u>neatly</u> . | Adverb of manner |
| 3. He <u>seldom</u> comes <u>here now</u> . | Adverb of number, Adverb of place, Adverb of time |
| 4. Your watch is not <u>quite</u> right. | Adverb of degree |
| 5. The teacher reached the school <u>late</u> . | Adverb of time |
| 6. She is <u>somewhat</u> better <u>today</u> . | Adverb of degree, Adverb of time |
| 7. She walked <u>carefully</u> . | Adverb of manner |
| 8. He cannot spell these words <u>correctly</u> . | Adverb of manner |

C. Fill in the blanks with the positive, comparative or the superlative degrees of adverbs given in the brackets :

- Raman came **earliest** of all.
- He came **earlier** than I expected .
- The father spoke **rudely** to his son.
- I drive the car **carefully**.
- He got up **earlier** than his father.
- Which of these boys lives **nearest** to the temple.
- She helped him **more** than me.
- He spoke **loudest** of all.

D. Fill in the blanks with the suitable adverbs:

- The letter is **neatly** written .
- The rain came on **suddenly**.
- Never speak **rudely**.
- He waited **patiently** at the station.
- You can see the patient **inside**; the nurse told the attendant.
- The children played **happily**.

E. Answer the following questions:

- What are adverbs of manner?

Ans. Adverbs of manner tell us how an action is done.

- What does a degree of comparison of adverb show ?

Ans. It shows the level or extent of an action (more, most, etc.).

- Define adverb of place.

Ans. An adverb of place tells us where an action is done.

- Define adverb of time.

Ans. An adverb of time tells us when an action is done.

9

Possessive Case of Nouns

A. Tick (✓) the right option :

- The Possessive Case of Singular Nouns is formed by adding :
(iii) 's
- The Possessive Case of Plural Nouns is formed in _____ ways.
(i) two

B. Write down the Possessive form of the following :

- | | |
|------------------------------|----------------------------|
| 1. The sister of Aman | Aman's sister |
| 2. The son of the doctor | The doctor's son |
| 3. The feathers of the birds | The birds' feathers |
| 4. The hair of the baby | The baby's hair |

C. Change the following into plurals :

- | | |
|------------------------|----------------------------|
| 1. The soldier's tanks | The soldiers' tanks |
| 2. The sheep's wool | The sheep's wool |
| 3. The hero's car | The heroes' cars |
| 4. The lady's dress | The ladies' dresses |

D. Answer the following questions :

- What is the Possessive Case of Noun?

Ans. The Possessive Case of a noun shows ownership or possession of a person, animal, place, or thing.

- How do we form the Possessive Case?

Ans. For **singular nouns** - add 's (e.g., boy - boy's)

For **plural nouns ending in s** - add ' (e.g., boys - boys')

For **plural nouns not ending in s** - add 's (e.g., children - children's)

10

Verbs

A. Tick (✓) the right option :

- A verb that requires an object to complete its meaning is called _____ :
(i) Transitive Verb
- Verbs which do not need an object to complete their sense, but make complete sense by themselves, are called :
(ii) Intransitive Verbs

3. A verb that joins a verb with its complement, is called a/an :
(iii) Linking Verb
4. Every verb has mainly _____ forms.
(ii) three

B. Fill in the blanks with Past Participle of the verbs given in the brackets :

1. The peon has **rung** the bell.
2. She **understood** the plot of the story.
3. We have **helped** the weak.
4. The boy has **shut** the door.
5. Monika **wrote** a letter yesterday.

C. Rewrite the following sentences using Present Participle forms of the verbs given in the brackets :

1. The boy is **laughing**.
2. The cold wind is **blowing**.
3. They are **learning** their lessons.
4. They are **dreaming**.
5. The teacher is **teaching** in the class.
6. She is **stitching** the clothes.

D. Change the following verbs into their Past form and Past Participle form :

| Verb | Past Form | Past Participle Form |
|-----------|----------------|----------------------|
| 1. Begin | began | begun |
| 2. Draw | drew | drawn |
| 3. Make | made | made |
| 4. Sleep | slept | slept |
| 5. Split | split | split |
| 6. Eat | ate | eaten |
| 7. Bet | bet | bet |
| 8. Forbid | forbade | forbidden |

E. Complete the following by supplying an object :

1. Ram eats – Ram eats **food**.
2. She broke – She broke **the glass**.
3. The dog bit – The dog bit **the man**.
4. Veena plays – Veena plays **cricket**.
5. Kamal loves – Kamal loves **his parents**.

F. Underline the verbs in the following sentences and write their kinds :

- | | |
|-------------------------------------|-------------------|
| 1. Riya <u>laughed</u> . | Intransitive Verb |
| 2. My mother <u>sent</u> me a gift. | Transitive Verb |
| 3. Krish <u>cuts</u> the rope. | Transitive Verb |
| 4. Some animals <u>swim</u> . | Intransitive Verb |
| 5. <u>Put</u> it down. | Transitive Verb |

G. Answer the following questions :

1. What is the difference between Transitive and Intransitive Verbs?

Ans. **Transitive Verb:** Needs an object to complete its meaning.

Intransitive Verb: Does not need an object; gives complete meaning by itself.

2. What is a Linking Verb?

Ans. A linking verb joins the subject with its complement and does not show action.

11 Verbs : Tenses

A. Fill in each blank with is, am or are:

1. I am happy here.
2. The children are talking to the teacher.
3. It is very cold today.
4. He is an honest man.
5. We like them because they are sincere.
6. Our team is ready for the match.
7. She is always punctual.
8. All the members of his family are here.
9. The owner of these flats is a big businessman.
10. He is his classmate.
11. Iron and coal are useful minerals.
12. She is at home.



B. Complete each sentence by using has or have:



1. I **have** a pencil.



2. My doll **has** a new dress.



3. Diya **has** a book.



4. Mr. Kant **has** many fish in his net.



5. These birds **have** their nests on this tree.



6. You **have** to stay after the class, Tony.



7. Sagar **has** a pet dog.



8. Pussy **has** a rosary in her hand.

C. Write the short form of the coloured words in the blanks.

1. I am **I'm** happy here.
2. We are **We're** going out.
3. She is **She's** very honest.
4. They have **They've** a big house.

D. Complete the sentence by filling the blank with is, am, are, was, were, shall, will, have, has, had or shall have.

1. The rose **is** red.
2. We **are** going to temple.
3. Divya **will** to go to Delhi next week.
4. She **is** angry with you.
5. This house before it was rebuilt last month **had** only two rooms.

6. The farmers **were** in the fields when it began to rain.
7. Most of our houses **have** sliding roofs.
8. A year **has** twelve months.
9. **Are** you unwell today?
10. I went to meet Raj last evening but he **was** rude to me.
11. My brother **will** join the college next year.
12. My grandmother **is** very weak.
13. Look at this girl with the balloons. She **has** a dirty face.
14. I **am** sorry to say that I **was** not present yesterday.
15. Maharana Pratap **was** a great ruler.
16. They **had** a party last night.
17. Tagore **was** a great poet.
18. **Will** you help me?
19. He **was** thirsty on the way.
20. It **is** 10 o'clock now.

E. Fill in the blanks with the correct form of the verbs given in the brackets.

1. The sun **rises** every morning.
2. These girls **took** their dance lessons last week.
3. My neighbour's dog **barks** at night.
4. Diya **sings** very melodiously.
5. She **makes** very silly mistakes.
6. The Shatabdi Express **reaches** Agra late in the evening.
7. Some bus drivers **drive** too fast, and **meet** with accidents.
8. She **understands** the aim of story.
9. Children, you always **make** noise in the class.
10. He **speaks** very fast but he **speaks** clearly in the meeting.
11. We **wear** our uniform when we **go** to school.
12. When the clock **struck** eleven, I **went** to bed last night.
13. They **will have** an outing next week.
14. Deepika **wrote** a letter to her grandmother yesterday.
15. We **will get up** early tomorrow morning.

F. Fill in the blanks with the Future Continuous Tense of the verbs given in the brackets :

1. Nisha and I **will be arranging** the tables in the hall.
2. We **will be meeting** her at Sadar Bazar this evening.
3. Mohit **will be dining** with us tonight.
4. We **will be going** fishing this weekend.
5. Neha **will be practising** for the debate competition then.
6. He **will be coming** late to the class today.

G. Answer the following questions :

1. Define verb.

Ans. A verb is a word that shows an action or tells what someone is doing.

2. Define present tense with two examples.

Ans. Present tense shows an action happening now or regularly.

3. Define past tense with two examples.

Ans. • She plays.
• I am eating.

4. Define future tense with two examples.

Ans. • He went home.
• She was happy.

12

Articles

A. Tick (✓) the right option :

1. There are _____ articles.

Ans. (ii) three

2. Iron is _____ useful metal.

Ans. (i) a

3. God made _____ Sun and _____ moon.

Ans. (ii) the

4. I was reading _____ Bible.

Ans. (iii) the

5. Jyoti left _____ hour ago.

Ans. (iii) an

B. Fill in the blanks with the suitable articles where necessary:

1. Honesty is a great virtue.
2. I read an interesting story in the Bible.
3. The children should drink — milk.
4. What a shame! You have killed an innocent animal.
5. I want a new dress.
6. The moon was not visible in the sky.
7. The Ganga rises in the Himalayas and falls in the Bay of Bengal.
8. I love — Indian music.
9. — Kalidas was a great poet.
10. A river flows into the sea.

C. Insert a, an or the where necessary:

1. **A** black and white dog is for sale.
2. They were **the** first to reach **the** station.
3. I was reading **the** Gita.
4. There are no stars in **the** sky.
5. **The** Ganga is a holy river.

13

Prepositions

A. Tick (✓) the right option :

1. A word which shows the position of a noun, is called :
(i) Preposition
2. A preposition is placed before a/an :
(ii) Noun

B. Fill in the blanks with appropriate prepositions :

1. The rabbit ran into the burrow.
2. Do not laugh at poor people.

3. They have invited their friends **to** birthday party.
4. I have kept the pencil box **beside** the water bottle.
5. The song was sung **by** Priya.
6. Never borrow money **from** others.
7. She is suffering **from** fever.
8. I will wait for you **at** the school gate.
9. He will return **in** a month.
10. He is not afraid **of** wild animals.
11. Distribute these toffees **among** the students.
12. Open your book **at** page 6.
13. The monkey fell **into** the well.
14. We have winter vacation **from** 14th December **to** 10th January.
15. He is proud **of** his son.

C. Underline the wrong prepositions used in the following sentences. Rewrite the sentences using correct prepositions in your notebook:

1. He was standing in the gate.

Ans. He was standing **at** the gate.

2. Distribute these mangoes to these ten children.

Ans. Distribute these mangoes **among** these ten children.

3. I am fond at milk.

Ans. I am fond **of** milk.

4. Our examination will begin at Tuesday.

Ans. Our examination will begin **on** Tuesday.

5. I agree to your proposal.

Ans. I agree **with** your proposal.

6. He enquired to his health.

Ans. He enquired **about** his health.

7. He deals at sugar.

Ans. He deals **in** sugar.

8. The lion came out on the cave.

Ans. The lion came out **of** the cave.

D. Use the given prepositions in sentences :

1. behind — **The cat is behind the door.**
2. in front of — **The car is parked in front of the house.**
3. beside — **She sat beside her friend.**
4. with — **I am going with my brother.**
5. after — **We will play after lunch.**

6. at — He is waiting at the bus stop.
 7. of — This is a cup of tea.
 8. from — She came from Delhi.

E. Answer the following questions :

1. What do you mean by preposition?

Ans. A preposition is a word that shows the relationship between a noun or pronoun and other words in a sentence.

2. Write some words which are known as preposition.

Ans. Some common prepositions are:

in, on, at, under, over, behind, between, among, from, to, with, of

14 Conjunctions

A. Tick (✓) the correct option :

1. A conjunction is a word used to join _____ .

Ans. (iii) words, group of words or sentences

2. Use the correct conjunction in the blanks:

(a) He worked hard _____ he failed.

Ans. (iii) but

(b) Work hard _____ you will fail.

Ans. (iii) otherwise

B. Encircle the conjunction in the following sentences:

- He thinks (that) he cannot pass.
- I will stay here (until) you return.
- He did not attend the meeting (as) it was raining.
- (Although) he loves her, he does not favour her.
- Come in (or) go out.
- Delhi is larger (than) Meerut.
- Work hard (if) you want to pass.
- Kamal will come (and) attend the wedding.

C. Fill in the blanks with appropriate conjunctions:

- He is going now **but** he will be back later.
- I am ill **so** I cannot go to school.

3. Kamal **and** Aman are friends.
4. Work hard **otherwise** you will fail.
5. You will fail **unless** you work hard.
6. I went to school **though** I knew no one would be there.
7. He has failed several times **but** he hopes to succeed.
8. He went to Delhi **but** he did not see the Lal Qila.
9. I did not attend the meeting **as** it was raining.
10. I looked after the home **with** she was away.

D. Join the following sentences using suitable conjunctions:

1. You can go to Goa by road. You can go by air.
You can go to Goa by road **or** you can go by air.

2. I'll give you a call. I reach home.

Ans. I'll give you a call **when** I reach home.

3. Don't let that man inside. He shows you his I-card.

Ans. Don't let that man inside **unless** he shows you his I-card.

4. Preeti is scared of dogs. His little brother is not.

Ans. Preeti is scared of dogs **but** her little brother is not.

5. The baby was crying. It was hungry.

Ans. The baby was crying **because** it was hungry.

6. Father scolded you. You were very naughty today.

Ans. Father scolded you **because** you were very naughty today.

7. Please buy me a pair of gloves. You go to the market.

Ans. Please buy me a pair of gloves **when** you go to the market.

8. Aryan arrived in the morning. You were in school.

Ans. Aryan arrived in the morning **when** you were in school.

E. Answer the questions:

1. Define conjunction.

Ans. A conjunction is a word used to join words, groups of words, or sentences. It helps to make sentences meaningful.

2. Write two examples of conjunctions.

Ans. Two examples of conjunctions are:

- **and** – joins similar words or ideas
- **but** – shows contrast

15

Interjections

A. Tick (✓) the right option:

1. A word which is used to express the sudden feeling or emotion of human beings, known as :
(iii) interjection
2. Which of the following mark is kept after the words of interjection?
(ii)!

B. Rewrite each sentence using the correct interjection for the word(s) given in colour:

1. It is sad our teacher is sick.

Ans. Alas! Our teacher is sick.

2. We are happy we have won the match.

Ans. Hurrah! We have won the match.

3. Do not disturb, the patient is seriously ill.

Ans. Hush! Do not disturb, the patient is seriously ill.

4. Are you listening? I am Ekta here.

Ans. Hello! Are you listening? I am Ekta here.

5. We are highly pleased, it's a fascinating news.

Ans. Wow! It's fascinating news.

6. You deserve all praise, you played very nicely.

Ans. Bravo! You played very nicely.

C. Fill in the blanks with the suitable interjections :

1. Wow! What a wonderful bird.
2. Bravo! What a hit.
3. Sh! Keep silence.
4. Alas! I have lost my job.
5. Ah! Carry on.

D. Is the interjection in the following sentences right? If not, correct them and write on the blank lines:

Ans. 1. No change – Hello! You are also here.

Ans. 2. Oh! How hot it is!

- Ans.** 3. Ouch! You are hurting me.
Ans. 4. Hurrah! I have won a lottery.
Ans. 5. Hello! I have not seen you since long.

E. Answer the following questions :

1. Define interjection.

Ans. An interjection is a word used to express sudden feelings or emotions.

2. What is the use of interjection?

Ans. Interjections are used to express emotions like joy, sorrow, surprise, pain, etc.

16 Punctuation

A. Tick (✓) the right option :

1. For separating a series of words, we have to use :

Ans. (iii) Comma

2. It is used at the end of an interrogative sentence :

Ans. (iii) Question mark

3. _____ are used to mark off the exact words of a speaker.

Ans. (i) Quotation marks

B. Supply all the necessary Stops and Capital Letters in the following sentences :

1. there are two apples in the basket

Ans. There are two apples in the basket.

2. where are you going

Ans. Where are you going?

3. february comes between january and march

Ans. February comes between January and March.

4. he is playing outside said divya

Ans. He is playing outside, said Divya.

5. she said this lesson is hard to learn

Ans. She said, "This lesson is hard to learn."

6. delhi the capital of india is situated on the bank of yamuna

Ans. Delhi, the capital of India, is situated on the bank of Yamuna.

7. what a surprise

Ans. What a surprise!

8. aryan is taller than sneha

Ans. Aryan is taller than Sneha.

C. Punctuate the following passages :

1. the sun the eight planets and their satellites make the solar system the sun is a star and all the planets move around it the earth is the only one planet where life is possible

Ans. The sun, the eight planets and their satellites make the solar system. The sun is a star, and all the planets move around it. The earth is the only one planet where life is possible.

2. we all know about the three monkeys of gandhiji one monkey keeps his eyes shut the second monkey keeps his ears shut the third monkey keeps his mouth shut

Ans. We all know about the three monkeys of Gandhiji. One monkey keeps his eyes shut, the second monkey keeps his ears shut, and the third monkey keeps his mouth shut.

3. my examination are over now i am feeling relaxed i have invited a few friends we shall have lunch together and enjoy music and play games

Ans. My examination are over. Now I am feeling relaxed. I have invited a few friends. We shall have lunch together and enjoy music and play games.

17

Direct and Indirect Speech

A. Tick (✓) the right option :

1. We may report the words spoken by a speaker in :

Ans. (iii) two ways

2. The way in which the words of a speaker are reported, is called:

Ans. (iii) indirect speech

3. A _____ is put after the reporting verb.

Ans. (iii) comma

4. If the reporting verb is in the present or future tense, the verb in the reported speech is :

Ans. (iii) is not changed at all

5. If the reporting verb is in the past tense, the tense in the reported speech is changed into :

Ans. (iii) corresponding past tense

B. Change the following sentences into indirect speech :

1. The officer said to me, "I am going to see my brother."

Ans. The officer told me that he was going to see his brother.

2. She said to him, "I cannot teach you."

Ans. She told him that she could not teach him.

3. Kamal said to Ekta, "We will go to Shimla."

Ans. Kamal told Ekta that they would go to Shimla.

4. He said to her, "You are not sincere to your work."

Ans. He told her that she was not sincere to her work.

5. He said, "It is raining here."

Ans. He said that it was raining there.

6. She said, "He is trying for a job."

Ans. She said that he was trying for a job.

7. Mayank said to Neetu, "You have made a mistake by giving up your job."

Ans. Mayank told Neetu that she had made a mistake by giving up her job.

18 Conversation

Note : This chapter is only for reading and practice.

19 Application Writing

1. Write an application to your Principal for leave of absence for four days due to sickness.

To,

The Principal,

B.K Public School, Delhi

Sub : Application for leave due to sickness

Sir/Madam,

I beg to say that I am suffering from fever and the doctor has advised me to take rest for four days. Therefore, I am unable to attend school.

Kindly grant me leave for four days from 21/02/2026 to 24/02/2026. I shall be thankful to you.

Please, grant me a leave for one week.

Thanking you.

Yours obediently,

Sandeep Jain

Class IV 'A'

2. Write an application to the Principal for leave of absence for a week as you have to go out to another city to attend your uncle's wedding.

To,

The Principal,

S.B Public School, Meerut

Sub : Application for leave

Sir/Madam,

I beg to say that I have to go to another city to attend my uncle's wedding. The function will last for a week, so I will not be able to attend school.

Kindly grant me leave for one week from 14/03/2026 to 20/03/2026. I shall be grateful to you.

Thanking you.

Yours obediently,

Manish Kumar

Class IV 'B'

20 Letter Writing

1. Write a letter to your friend about a birthday present.

S-45, Green Park

Delhi

10th August, 20025

My Dear Anjali,

I hope you are fine and happy in your new country. I was very sad to hear that you have gone there forever. I miss you a lot.

How is your new school? Have you made new friends? I hope you are enjoying your new life. Please do not forget me.

Write to me soon.

Yours lovingly,

Shivani

2. Write a letter to your father requesting him to send ₹ 200 for a school picnic.

A-12, Shastri Nagar

Kanpur

5th September, 2025

My Dear Father,

I am fine here and hope you are also fine. I want to inform you that our school is organizing a picnic next week.

I wish to join it with my friends. Kindly send me ₹200 for the picnic expenses.

Please convey my regards to Mother.

Yours lovingly,

Ravi

3. Write a letter to your elder brother describing the Independence Day celebration of your school.

B-20, Model Town

Lucknow

16th August, 2025

Dear Brother,

I hope you are doing well. I am writing this letter to tell you about our Independence Day celebration in school.

We celebrated it with great joy. Our Principal hoisted the national flag. We sang the national anthem. There were many cultural programs like dances and speeches.

It was a very enjoyable day.

Yours affectionately,

Ankit

4. Write a letter to your father informing him of your success in winning a prize at a debate.

C-15, School Hostel

Jaipur

20th June, 2025

My dear Father,

I am fine here and hope you are also fine. I am very happy to tell you that I have won first prize in a debate competition in my school.

Everyone appreciated me. I worked very hard for it. I hope you will be proud of me.

Give my regards to Mother.

Yours lovingly,

Sohan

21 Story Writing

A. Look at the following pictures and write a story in your own words.

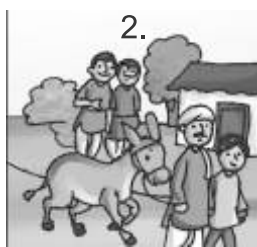

One day, a man was walking with his donkey through a village. Some people laughed at him and said he was foolish to walk while the donkey was free.

So, the man sat on the donkey. After some time, other people said that he was cruel to make the donkey carry his weight.

Then, the man asked his son to sit on the donkey. Soon, other people criticized them again.

Finally, both the man and his son sat on the donkey. The people again laughed and said they were overloading the poor animal.

In the end, the man understood that people will always say something. So, he decided to do what he thought was right.

Moral : Do not listen to everyone. Use your own mind.

B. Look at the following picture and write a story in your own words :

Once, a monkey lived on an apple tree with juicy red apples. One day, a crocodile came and asked for apples. The kind monkey shared them and even sent some for the crocodile's wife.



After tasting the apples, the wife wished to eat the monkey's heart and forced the crocodile to bring it. Though confused, the crocodile agreed and invited the monkey to his home.

On the way, in the middle of the river, the crocodile revealed his plan. The clever monkey quickly said he had left his heart on the tree. The crocodile took him back, and the monkey jumped to safety.

He then called the crocodile foolish for believing him and warned him about betrayal.

Moral: Be careful whom you trust; a friend can also become an enemy.

22 Essay Writing

Write a composition on each of the following :

1. Life in Village

Life in a village is simple and peaceful. Villages are full of greenery and fresh air. People live close to nature.

Most villagers are farmers. They grow crops and take care of animals. Their life depends on nature.

There is less pollution and noise in villages. The environment is clean and healthy. People feel relaxed there.

People in villages are kind and helpful. They live together like a family. Everyone helps each other.

However, there are fewer schools and hospitals. Still, village life is calm and happy. Many people love village life.

2. Good Manners

Good manners are very important in our life. They show how good a person we are. Everyone likes well-mannered people.

We should respect our elders and teachers. We must be kind and polite to others. Helping others is also a good habit.

We should always say "please", "thank you" and "sorry". These words show respect and kindness. They make others happy.

We should speak softly and behave properly. We must not use bad words or fight with anyone. Good behaviour is important.

Good manners make us a good person. They help us in school and society. Everyone respects a well-mannered child.

3. My Pet Animal

I have a pet dog. His name is Tommy. He is very cute and friendly. He is very active and playful. He loves to run and play with me. I enjoy spending time with him.

Tommy guards our house at night. He keeps us safe from strangers. He is very loyal.

He likes to eat biscuits and drink milk. I take care of his food and health. I also give him a bath.

I love my pet very much. He is like a member of our family. He makes me very happy.

4. India

India is my country. It is a very big and beautiful country. I love my country very much.

People of many religions and languages live here. They celebrate different festivals together. This shows unity in diversity.

New Delhi is the capital of India. India has many rivers, mountains, and forests. It is rich in culture.

India is famous for its traditions and history. Many great leaders were born here. They made our country proud.

We should respect our country. We must keep it clean and safe. I am proud to be an Indian.

5. A Book Fair

A book fair is a place where many books are sold. People come to buy and read books. It is very interesting.

I visited a book fair with my parents. There were many stalls of different books. The fair was very crowded.

I saw storybooks, comics, and school books. All the books were arranged nicely. I enjoyed looking at them.

Many children and adults were there. Everyone was happy and excited. Some people were reading books there.

I bought a few books for myself. It was a wonderful experience. I want to visit a book fair again.

6. A Cricket Match

Cricket is my favourite game. I watched a cricket match with my friends. It was very exciting.

Two teams were playing very well. The players hit many runs and wickets. Everyone was cheering.

The stadium was full of people. They were shouting and clapping loudly. The match became very interesting.

Our favourite team played very well. They scored many runs and won the match. We felt very happy.

We enjoyed the match a lot. Cricket is a fun and popular game. I love watching cricket.

7. Importance of Trees

Trees are very important for us. They give us oxygen to breathe. Without trees, life is not possible.

Trees give us fruits, flowers, and wood. They provide shade and cool air. They make the environment beautiful.

Trees help to control pollution. They keep the air clean and fresh. They also bring rain.

Many birds and animals live on trees. Trees give them shelter and food. They are very useful.

We should plant more trees. We must not cut them unnecessarily. Trees are our best friends.

8. The Rainy Day

A rainy day is very enjoyable. The sky becomes cloudy and cool winds blow. It looks very pleasant.

People use umbrellas and raincoats. The roads become wet and muddy. Water collects in many places.

Children love to play in the rain. They float paper boats in water. It is very fun.

Sometimes heavy rain causes problems. Streets get flooded and people face difficulty. Traffic also stops.

I enjoy rainy days very much. I like eating hot snacks at home. A rainy day is always special.

23 Unseen Passages

UNSEEN PASSAGES-1

1. How many languages are spoken in our country?

Ans. Many languages are spoken in our country.

2. Which languages are recognised by the Constitution of India?

Ans. Assamese, Bengali, Gujarati, Hindi, Kannada, Kashmiri, Konkani, Malayalam, Manipuri, Marathi, Nepali, Oriya, Punjabi, Sanskrit, Sindhi, Tamil, Telugu, Urdu, Bodo, Dogri, Maithili.

3. Which languages are written from right to left?

Ans. Kashmiri, Sindhi and Urdu.

4. Which is the official language of India?

Ans. Hindi is the official language of India.

5. When was English used as official language in India?

Ans. During the British rule.

UNSEEN PASSAGES-2

1. What did the mouse do when the lion was asleep?

Ans. It ran on the body of the lion.

2. What did the mouse say when the lion was about to kill it?

Ans. "Please sir, do not kill me. Someday I may help you."

3. Why did the lion laugh loudly?

Ans. Because he thought a small mouse could not help him.

4. Who helped the lion?

Ans. The mouse.

5. How did the mouse help the lion?

Ans. It cut the net with its sharp teeth and freed the lion.

6. What is the moral of the story?

Ans. Even small creatures can help the big ones.

UNSEEN PASSAGES-3

1. Where did the two goats meet?

Ans. On a narrow bridge.

2. What did the first goat say?

Ans. "Go back, I am stronger than you."

3. What did the second goat say?

Ans. "Let me pass." / "You are not stronger."

4. Could they cross the bridge?

Ans. No, not at first.

5. What did the wise goat say?

Ans. "Stop! If we fight, we will fall into the river. I will lie down and you walk over me."

6. Were they able to pass?

Ans. Yes, they passed easily.

UNSEEN PASSAGES-4

1. What is an earthquake?

Ans. It is a natural calamity.

2. What do we read about the earthquakes in the newspapers?

Ans. That many people lose their lives and damage occurs.

3. What does an earthquake cause?

Ans. Destruction to life and property.

4. What are earth tremors?

Ans. Shaking of the earth during an earthquake.

5. What do people feel under their feet during an earthquake?

Ans. The ground rocking.

6. When did an earthquake occur at Kuchch in Gujarat?

Ans. On Republic Day in 2001.

7. Give a suitable title to the passage.

Ans. Earthquakes

A. Tick (✓) the right option:

1. A sentence is a group of words that makes _____.

Ans. (iii) complete sense

2. There are _____ kinds of sentences.

Ans. (i) four

3. 'Who told a lie?' This sentence is _____.

Ans. (ii) interrogative

B. Say which of the coloured groups of words are phrases and which are clauses:

1. The man, who was ill, lay on a bed in the hospital.

Ans. **who was ill** – Clause

in the hospital – Phrase

2. The boy was wearing a chain of gold and shoes that were made of leather.

Ans. **a chain of gold** – Phrase

that were made of leather – Clause

3. What you have said is not correct.

Ans. **What you have said** – Clause

4. Nishant met Aditya, who was carrying a big basket, in the market.

Ans. **who was carrying a big basket** – Clause

in the market – Phrase

5. The travellers, who were hungry and tired, wanted to go to a hotel without any further delay.

Ans. **who were hungry and tired** – Clause

without any further delay – Phrase

6. Raj, a good swimmer, swam easily across the river.

Ans. **a good swimmer** – Phrase

7. The boy, who had won the race, was given a crown of laurel leaves.

Ans. **who had won the race** – Clause

8. After he returned from Kolkata, Aman fell ill.

Ans. **After he returned from Kolkata** – Clause

C. Re-write the following sentences by using suitable punctuation marks and capital letters wherever necessary:

1. that is my brothers shirt think

That is my brother's shirt, I think.

2. delhi is the capital of india

Delhi is the capital of India.

3. where do you live

Where do you live?

4. how beautiful the building looks

How beautiful the building looks!

- | | |
|---|--|
| 5. oh that is great news | Oh, that is great news! |
| 6. raman brings a pen | Raman brings a pen. |
| 7. priya is a beautiful girl | Priya is a beautiful girl. |
| 8. divya wants to take teaching lessons | Divya wants to take teaching lessons. |

D. Read the following sentences and say whether they are 'Assertive', 'Interrogative', 'Imperative' or 'Exclamatory' sentences:

- | | |
|------------------------------------|----------------------|
| 1. Did you lose the match? | Interrogative |
| 2. March forward. | Imperative |
| 3. I have done my work. | Assertive |
| 4. Why do you make a noise? | Interrogative |
| 5. He did not write a letter. | Assertive |
| 6. Do you attend your class daily? | Interrogative |
| 7. Oh! He is no more. | Exclamatory |
| 8. Shiv has taught me! | Exclamatory |
| 9. What a naughty boy he is. | Exclamatory |
| 10. Please help me in this matter. | Imperative |

2

Parts of a Sentence: Subject and Predicate

A. Tick (✓) the right option :

1. The Subject and the _____ are the two parts of a sentence.

Ans. (i) Predicate

2. The person, animal or thing we speak about is called the :

Ans. (i) Subject

3. All the sentences have _____.

Ans. (iii) The subject and the predicate both

B. Separate the Subject and the Predicate in the following sentences :

1. The old woman posted a letter.

Ans. **Subject:** The old woman **Predicate:** posted a letter

2. The shirt costs only 300 rupees.

Ans. **Subject:** The shirt **Predicate:** costs only 300 rupees

3. The Bible is a holy book.

Ans. **Subject:** The Bible **Predicate:** is a holy book

4. Children are swimming.

Ans. **Subject:** Children **Predicate:** are swimming

5. This book is mine.

Ans. **Subject:** This book **Predicate:** is mine

6. The moon moves round the Earth.

Ans. **Subject:** The moon **Predicate:** moves round the Earth

7. The children were playing hide-and-seek.

Ans. **Subject:** The children **Predicate:** were playing hide-and-seek

C. Match the Subjects from Column 'A' with the Predicates in Column 'B' :

Column A

Column B

- | | | |
|------------------|-----|-----------------------------------|
| 1. Mercury | (f) | is the planet closest Sun |
| 2. The elephant | (g) | is the largest land animal |
| 3. To find fault | (d) | is easy |
| 4. The dog | (a) | played with a ball |
| 5. The painter | (c) | has painted my house |
| 6. A black snake | (b) | entered the room |
| 7. strawberries | (e) | are bright red in colour |

D. Make a sentence about each of the following Subject :

- | | |
|-------------------------|---|
| 1. children | Children are playing in the park. |
| 2. mangoes | Mangoes are very sweet. |
| 3. Subhash Chandra Bose | Subhash Chandra Bose was a great leader. |
| 4. nepoleon | Napoleon was a famous emperor. |
| 5. computer | A computer is a useful machine. |

E. Answer the following questions :

1. What is the Subject part of a sentence?

Ans. The subject is the person, animal or thing that we talk about in a sentence.

2. What is the Predicate part of a sentence?

Ans. The predicate tells something about the subject or describes what the subject does.

3

Noun and Its Kinds

A. Tick (✓) the right answer :

1. There are _____ kinds of nouns.

Ans. (ii) five

2. Honesty, beauty, and height are _____ nouns.

Ans. (iii) abstract

3. A noun that gives a common name to a person place or thing is called a :

Ans. (iii) common noun

4. A collection of fish is called :

Ans. (iii) shoal

5. The army is a collection of :

Ans. (ii) soldiers

6. A number of judges is called :

Ans. (iii) bench

B. Make abstract nouns from the following words :

- | | | | |
|--------------|------------------|----------|------------------|
| 1. fair | fairness | 2. pure | purity |
| 3. child | childhood | 4. agree | agreement |
| 5. grow | growth | 6. wish | wish |
| 7. beautiful | beauty | 8. obey | obedience |
| 9. quick | quickness | 10. busy | busyness |

C. Fill in the blanks with the noun form of the words giving in the brackets :

1. The country cannot progress unless there is unity among the people .
2. Poverty is a great curse.
3. He gave a warm reception to the guests.
4. His decision proved to be correct .
5. He heard my story with patience.
6. He is known for his justice

4

Singular and Plural Nouns

A. Tick (✓) the right option :

1. Nouns are used in _____ numbers.

Ans. (i) two

2. A Noun which names one person, is said to be in the :

Ans. (ii) Singular Number

3. The plural of calf is :

Ans. (ii) calves

B. Change the following Singular Nouns into their Plural :

- | | | | |
|------------|-----------------|-----------|----------------|
| 1. lemon | lemons | 2. cow | cows |
| 3. bush | bushes | 4. shirt | shirts |
| 5. box | boxes | 6. gas | gases |
| 7. army | armies | 8. valley | valleys |
| 9. leaf | leaves | 10. hoof | hoofs |
| 11. potato | potatoes | 12. goose | geese |

C. Change the following Plural Nouns into their Singular :

- | | | | |
|-------------|---------------|-----------------|-------------------|
| 1. joys | joy | 2. keys | key |
| 3. sheep | sheep | 4. ways | way |
| 5. wives | wife | 6. gulfs | gulf |
| 7. storeys | storey | 8. oxen | ox |
| 9. children | child | 10. feet | foot |
| 11. armies | army | 12. sons-in-law | son-in-law |

D. Change the following sentences from the Singular into the Plural :

- | | |
|--|---|
| 1. The boy used axe to cut off the tree. | The boys used axes to cut off the trees. |
| 2. Orange is a fruit. | Oranges are fruits. |
| 3. We need a dozen sheet. | We need dozens of sheets. |
| 4. The child played the piano. | The children played the piano. |
| 5. Put the book in your bag. | Put the books in your bags. |
| 6. The mouse had made a hole in the box. | The mice had made holes in the boxes. |
| 7. The wolf killed a sheep. | The wolves killed sheep. |
| 8. His shirt is dirty. | Their shirts are dirty. |

E. Change the following sentences from the Plural into the Singular :

- | | |
|--|--|
| 1. These actors play the parts of heroien. | This actor plays the part of heroine. |
| 2. The women cleaned their houses. | The woman cleaned her house. |
| 3. The girls worked hard. | The girl worked hard. |
| 4. Potatoes are my favourite vegetable. | Potato is my favourite vegetable. |
| 5. Invertors need batteries. | Invertor needs battery. |
| 6. The men carried handkerchieves. | The man carried a handkerchief. |
| 7. The doctor pulled out the aching teeth. | The doctor pulled out the aching tooth. |
| 8. The monkey are sitting on the trees. | The monkey is sitting on the tree. |

F. Answer the following questions :

1. What do you understand by the Singular Number of Nouns ?

Ans. Singular Number of nouns refers to a noun that names one person, place, animal or thing.

2. What are the Plural Nouns?

Ans. Plural nouns are those nouns that refer to more than one person, place, animal or thing.

5

Pronouns

A. Tick (✓) the right option :

1. A pronoun is a word which is used in place of _____.

Ans. (iii) a noun

2. There are _____ kinds of pronouns.

Ans. (i) eight

3. There are _____ persons.

Ans. (ii) three

4. I don't know _____ you mean.

Ans. (ii) what

5. _____ is your pen?

Ans. (i) which

B. Fill in the blanks with appropriate personal pronouns:

1. He/She is my best friend.
2. She taught my brother.
3. He/She didn't go to the school.
4. Where are you going? Have you ever been there.
5. The teacher will beat you, if you do not do your work.
6. I am waiting for you. Where had you gone?
7. Kamal is a good boy. My brother will teach him.
8. My dog loves me.
9. They are my friends but they do not listen to what I say.
10. We didn't wait for him/them.

C. Fill in the blanks with suitable Interrogative Pronouns:

1. Who is your mother?
2. Whose son are you?
3. Which is your pen?
4. What is your name?
5. What do you want?

D. Answer the following questions :

1. Define pronoun.

Ans. A pronoun is a word used in place of a noun or noun expression.

2. What is interrogative pronoun? Give two examples.

Ans. Interrogative pronouns are used to ask questions.

Examples: who, what

3. What is emphasising pronoun? Give two examples.

Ans. Emphasising pronouns are used to give emphasis to a noun or pronoun.

Examples: himself, yourself

6

Gender

A. Tick (✓) the right option :

1. A noun that denotes both a male and a female, is known as :

Ans. (iii) common gender

2. A noun that denotes a non-living thing is said to be of the :

Ans. (ii) neuter gender

B. Rewrite the following sentences using nouns and pronouns of the opposite gender (Make other changes if necessary) :

1. The lion killed the daughter of a washerman.

Ans. The lioness killed the son of a washerwoman.

2. The king went into the hall. He ate breakfast.

Ans. The queen went into the hall. She ate breakfast.

3. My nephews and brothers come to see him.

Ans. My nieces and sisters come to see her.

4. The prince was riding on a white horse.

Ans. The princess was riding on a white mare.

5. A windower is he who has lost his wife.

Ans. A widow is she who has lost her husband.

C. Underline the Masculine Gender and change them into Feminine Gender (Make other changes if necessary) :

1. The priest thanked the God.

Ans. The priestess thanked the Goddess.

2. My son helped me in my work.

Ans. My daughter helped me in my work.

3. The prince was walking in the garden.

Ans. The princess was walking in the garden.

4. My daughter is a good doctor.

Ans. My daughter is a good doctor.

5. The salesman showed my father a variety of shirts.

Ans. The saleswoman showed my mother a variety of shirts.

D. Answer the following questions :

1. What does the Masculine Gender denote?

Ans. Masculine gender denotes a noun that refers to a male.

2. What do you mean by the Feminine Gender?

Ans. Feminine gender refers to a noun that denotes a female.

3. What is the difference between the Common Gender and the Neuter Gender?

- Ans.**
- **Common Gender:** Refers to both male and female (e.g., teacher, child)
 - **Neuter Gender:** Refers to non-living things (e.g., book, pen)

7

Adverbs

A. Tick (✓) the right option :

1. The Adverb which tells where or at what place an action is done, called :

Ans. (b) Adverb of Place

2. An Adverb of Number tells _____ an action is done.

Ans. (c) how often

3. Which adverb is used to ask a question?

Ans. (c) Interrogative Adverb

B. Pick out the Adverbs in the following sentences. Underline the Verb, Adjective or Adverb to which they are added. Also point out what kind of Adverb they are :

1. I rarely play badminton. **Type:** Adverb of Frequency

2. We should treat our guests respectfully. **Type:** Adverb of Manner

3. The vacations will begin tomorrow. **Type:** Adverb of Time

4. Are you going outside now? **Type:** Adverb of Place

5. The doctor will come back in a few minutes. **Type:** Adverb of Time

6. They play hockey regularly. **Type:** Adverb of Frequency

7. I am waiting for you. Please, come outside. **Type:** Adverb of Place

8. The children behaved well at the party. **Type:** Adverb of Manner

C. Add -ly to these Adjectives to form Adverbs and use them in sentences. (In certain case you may have to alter the spellings slightly)

| Adjective | Adverb | Sentence |
|-----------|----------|--------------------------|
| heart | heartily | He laughed heartily. |
| bad | badly | He played badly. |
| neat | neatly | She writes neatly. |
| hungry | hungrily | The dog ate hungrily. |
| angry | angrily | She spoke angrily. |
| lazy | lazily | He walked lazily. |
| slow | slowly | The turtle moves slowly. |
| simple | simply | He explained simply. |

D. Write the Comparative and the Superlative Degree of the following words :

| Positive | Comparative | Superlative |
|--------------|----------------|----------------|
| 1. beautiful | more beautiful | most beautiful |

| | | | |
|----|--------|----------|-----------|
| 2. | late | later | latest |
| 3. | soon | sooner | soonest |
| 4. | pretty | prettier | prettiest |
| 5. | fast | faster | fastest |
| 6. | clear | clearer | clearest |
| 7. | good | better | best |
| 8. | loud | louder | loudest |

E. Answer the following questions :

1. What does Adverb of Place tell us?

Ans. It tells us where or at what place an action happens.

2. Which Adverbs are known as Adverbs of Degree?

Ans. Adverbs that tell how much or to what extent are called Adverbs of Degree (e.g., very, quite, almost).

3. What is the use of Interrogative Adverb?

Ans. It is used to ask questions (e.g., how, why, where).

8

Comparison of Adjectives

A. Fill in the blanks with the correct adjectives:

- Ritu is **taller** than her sister.
- You have **much** work to do. Go after **some** time,
- Can you spare **some** time for me?
- He did not spare even **a little** money for the beggar.
- The Pacific is the **deepest** ocean in the world.
- See me **later**.
- The **whole** book was torn.
- Patience is a **great** virtue.

B. Supply the missing degree of the adjective:

| | | |
|--------|-----------------|----------------|
| pretty | prettier | prettiest |
| fat | fatter | fattest |
| bad | worse | worst |
| cosy | cosier | cosiest |
| wise | wiser | wisest |

C. Fill in the blanks with the correct degree of the adjective given in the brackets:

- Today it is **colder** than it was yesterday.

2. Prevention is **better** than cure.
3. Iron is **more usefu** than gold.
4. He gave me **little** trouble.
5. Renu has **many** friends in school.
6. Which is the **taller** of the two brothers?
7. This work is **more important** than that.
8. She is **smarter** than her brother.
9. America is **richer** than any other country of the world.
10. A giraffe is **taller** than a zebra.

D. Rewrite each sentence correctly.

1. Priyanka is the oldest daughter in the family.

Ans. Priyanka is the eldest daughter in the family.

2. Of the two players the best one will win.

Ans. Of the two players, the better one will win.

3. Deepak took the biggest half of the mango.

Ans. Deepak took the bigger half of the mango.

4. Sourva is senior than Rinku in office.

Ans. Sourva is senior to Rinku in office.

5. Of all the metals gold is costlier.

Ans. Of all the metals, gold is the costliest.

6. My brother is older than me.

Ans. My brother is older than me.

7. Garima has less friends than I.

Ans. Garima has fewer friends than I.

E. Use the correct degree of the adjective given in the brackets against each sentence :

1. Lead is the **heaviest** of all metals.
2. This is the **easiest** exercise in the book.
3. You can take the **heaviest** of all those books.
4. He is my **eldest** son.
5. Paris is **more beautiful** than Berlin.
6. This medicine tastes **more bitter** than the medicine in that bottle.
7. Laxmibai was **braver** than any other Indian woman.

7. Our team has **better** batsman than bowlers.

9. Ajay is **more economical** than his father.

F. Rewrite each sentence using the adjective given in colour to mean the opposite in meaning.

1. Africa is the **brightest** of all the continents in the world.

Ans. Africa is the **darkest** of all the continents in the world.

2. The moon is the **farthest** planet from the earth.

Ans. The moon is the **nearest** planet to the earth.

3. She is **more intelligent** than Neetu.

Ans. She is **less intelligent** than Neetu.

4. Delhi is **less polluted** than Mumbai.

Ans. Delhi is **more polluted** than Mumbai.

5. This is the **most crowded** of all the trains going to Delhi.

Ans. This is the **least crowded** of all the trains going to Delhi.

6. It is a **bright** night.

Ans. It is a **dark** night.

7. She is the **prettiest** of all her friends.

Ans. She is the **ugliest** of all her friends.

9

Determiners

A. Tick (✓) the right option:

1. _____ are words which identify or specify a noun in some way.

Ans. (ii) Determiners

2. In 'simple question' the determiner is:

Ans. (iii) both of these

3. A, an and the are:

Ans. (i) articles

4. There are _____ kinds of determiners.

Ans. (iii) six

B. Fill in the blanks with a, an, the where necessary:

1. I am a five year old girl.

2. I do not have a friend.
3. He bought an egg.
4. A white and a black cow were grazing.
5. Man is mortal.
6. It is not an easy task.

C. Fill in the blanks with correct articles:

1. My elder sister is _____ teacher .

Ans. (i) a

2. There lived a rabbit in a forest. _____ rabbit was very kind.

Ans. (ii) The

3. _____ rich are happy.

Ans. (iii) The

D. Fill in the blanks with some or any:

1. Buy some shirt. They are all made from superior quality cloth.
2. I don't want any mangoes.
3. Some medicines should never be taken on an empty stomach.
4. She was too tired to do any work.
5. May I have some bread or butter please?
6. Can you lend me some books to read?

E. Fill in the blanks with either, neither, each, every. In some cases more than one choice is possible:

1. I have read every book in the library.
2. You can buy either pair of shoes.
3. I have read every word of your story.
4. It wasn't a good match. Neither team played well.
5. There are two roads from here. You can take either road.

10

Use of Articles

A. Tick (✓) the right option :

1. Which article is used before a word beginning with a vowel sound?

Ans. (ii) 'an'

2. The article which points out some particular thing, is known as :

Ans. (ii) Definite Article

3. Article 'a' is used before the words beginning with a :

Ans. (ii) Consonant sound

B. Insert a, an and the as required :

1. An orange grows on a tree.
2. An old man lost an arm in an accident.
3. A cat has a tail.
4. He is an honour to his profession.
5. We drank the soup with a spoon.
6. A good boy always speaks the truth.

C. Rewrite the following sentences correctly using articles :

- | | |
|---|---|
| 1. This is fine cricket set. | This is a fine cricket set. |
| 2. The mother gave me a useful pen. | The mother gave me a useful pen. |
| 3. Have you read <i>Ramayana</i> ? | Have you read the <i>Ramayana</i>? |
| 4. My servant is a honest man. | My servant is an honest man. |
| 5. My mother is M.B.B.S. doctor. | My mother is an M.B.B.S. doctor. |
| 6. Boy who lives next door is my classmate. | The boy who lives next door is my classmate. |

D. Insert articles where necessary :

- | | |
|---|---|
| 1. Why does fan move so fast? | Why does the fan move so fast? |
| 2. Tell me joke. | Tell me a joke. |
| 3. My favourite book is <i>Geeta</i> . | My favourite book is <i>Geeta</i>. (No article needed) |
| 4. My father is doctor and mother is teacher. | My father is a doctor and my mother is a teacher. |
| 5. It was delicious biscuit. | It was a delicious biscuit. |

E. Answer the following questions :

1. What is Indefinite Article? Where is it used?

Ans. Indefinite Articles are 'a' and 'an'. They are used for general or non-specific persons or things.

'a' is used before consonant sounds (a boy)

'an' is used before vowel sounds (an apple)

2. What do you understand by Definite Article?

Ans. The Definite Article is 'the'. It is used to refer to a specific or particular person, place or thing that is already known or mentioned before.

11

Verbs

A. Tick (✓) the right option :

1. The past form of the verb 'swim' is _____.

Ans. (i) swam

2. A verb which requires an object after it to complete its sense, is called a/an :

Ans. (i) Transitive Verb

3. A verb which does not require an object to complete its sense, is called a/an :

Ans. (iii) Intransitive Verb

4. All the verbs have _____.

Ans. (ii) three forms

B. Pick out the Verbs in the following sentences and say in each case whether the verb is used as Transitive, Intransitive or Incomplete Verb:

| | Verb | Verb Type |
|---|-------------|-------------------|
| 1. The Sun rises every morning. | rises | Intransitive Verb |
| 2. Father reads the newspaper daily. | reads | Transitive Verb |
| 3. She dropped the ring into the pool. | dropped | Transitive Verb |
| 4. Soon the sky grew dark. | grew | Incomplete Verb |
| 5. Rohan plays hockey. | plays | Transitive Verb |
| 6. Mother is cooking food. | cooking | Transitive Verb |
| 7. All your answers are wrong. | are | Incomplete Verb |
| 8. She became happy. | became | Incomplete Verb |
| 9. Principal seems annoyed. | seems | Incomplete Verb |
| 10. He seems innocent. | seems | Incomplete Verb |
| 11. The bus was running at a great speed. | was running | Intransitive Verb |
| 12. The baby cried when he could not find his ball. | cried | Intransitive Verb |

C. Complete the sentences by choosing the correct form of the verb from the brackets:

- Kamal is swimming.
- The monkey looks at the door.
- Disha was speaking.
- I am walking.
- He tore his book.
- The women go to school.
- They had spoken.

8. The farmer **ploughed** the field.
9. We are **singing**.
10. They have been **dancing**.

D. Rewrite the following sentences changing the verbs to the Past Tense :

- | | |
|----------------------------------|--|
| 1. The snake bites the child. | The snake bit the child. |
| 2. Sachin wins the first prize. | Sachin won the first prize. |
| 3. The girls play in the garden. | The girls played in the garden. |
| 4. The hunter shoots the tiger. | The hunter shot the tiger. |
| 5. Mother cooks food. | Mother cooked food. |
| 6. She writes letter. | She wrote letter. |
| 7. They help the needy. | They helped the needy. |
| 8. The peon rings the bell. | The peon rang the bell. |

E. Write Past and Past Participle forms of the following verbs :

| Present | Past | Past Participle | Present | Past | Past Participle |
|----------------|-------------|------------------------|----------------|-------------|------------------------|
| arrive | arrived | arrived | begin | began | begun |
| honour | honoured | honoured | apply | applied | applied |
| turn | turned | turned | hide | hid | hidden |
| swim | swam | swum | make | made | made |
| buy | bought | bought | lie | lay | lain |
| Present | Past | Past Participle | Present | Past | Past Participle |
| catch | caught | caught | overcome | overcame | overcome |
| go | went | gone | cut | cut | cut |

F. Underline the verb and say what kind it is :

- | | |
|--|--------------------------|
| 1. My mother <u>is</u> very happy today. | Incomplete Verb |
| 2. Megha <u>swims</u> in the river everyday. | Intransitive Verb |
| 3. Cow <u>eats</u> grass and straw. | Transitive Verb |
| 4. She <u>eats</u> fastly. | Intransitive Verb |
| 5. Priya <u>bought</u> a pencil. | Transitive Verb |
| 6. This <u>is</u> a beautiful flower. | Incomplete Verb |

G. Answer the following questions :

1. What is the difference between Transitive and Intransitive Verbs ?

Ans. Transitive Verb: Needs an object to complete its meaning.

Example: She reads a book.

Intransitive Verb: Does not need an object.

Example: She sleeps.

2. What do you know about Strong and Weak Verbs?

Ans. Weak Verbs: Form past by adding -ed, -d, -t

Example: play – played

Strong Verbs: Change vowels

Example: go – went – gone

3. What are the different forms of a verb?

Ans. A verb has mainly three forms:

1. Present (V1), 2. Past (V2), 3. Past Participle (V3)

12 The Present Tense

A. Tick (✓) the right option :

1. In the simple present tense, _____ of the verb is used.

(iii) first form

2. Tick (✓) the correct form of the verb:

- (i) (a) Mohan (sing/sings) a song.
(b) Riya (do not/does not go) for swim.
(c) (Does/Do) they sing a song?
- (ii) (a) Rohan has (go/gone) to Delhi.
(b) She (is/am) writing a letter.
(c) I (is/am) watching TV.

B. Fill in the blanks with the simple present tense forms of the verbs given in the brackets:

1. He goes to temple daily.
2. She writes a letter.
3. I play in the park.
4. She puts on a nice dress.
5. Birds fly in the sky.

C. Fill in the blanks with the present continuous forms of the verbs given in the brackets:

1. I **am going** to school today.
2. Riya **is singing** a song.
3. They **are eating** the dinner.
4. The birds **are flying** in the sky.

D. Fill in the blanks with the present perfect forms the verbs given in the brackets:

1. The police **have caught** the thief.
2. I **have done** my work.
3. It **has rained**
4. Tanu and Chinki **have gone** to the library.
5. My servant **has cooked** food.

E. Rewrite the following sentences after changing the verbs into the present continuous tense:

- | | |
|---------------------------------------|--|
| 1. The kids have broken the window. | The kids are breaking the window. |
| 2. She plays with her sister. | She is playing with her sister. |
| 3. Tanya has eaten her dinner. | Tanya is eating her dinner. |
| 4. The boys have learnt their lesson. | The boys are learning their lesson. |
| 5. The train has arrived. | The train is arriving. |

13

The Past Tense

A. Tick (✓) the correct option :

1. He _____ to Agra yesterday.

Ans. (ii) went

2. Fill in the blanks by using past continuous form of the verb :

(a) I _____ a letter .

Ans. (i) was writing

(b) They _____ a song in their room.

Ans. (i) were singing

3. Fill in the blanks by using past perfect tense:

(a) He _____ a letter before you came.

Ans. (iii) had written

(b) Sagar _____ the lesson before the teacher came.

Ans. (iii) had learnt

14

The Future Tense

A. Tick (✓) the right option :

1. Shaan _____ a story.

Ans. (ii) will tell

2. I _____ to Agra tomorrow .

Ans. (i) will go

Fill in the blanks by using future continuous form of the verb:

(a) Jiya _____ a letter to her friend.

Ans. (iii) will be writing

(b) Prashant _____ his sister.

Ans. (ii) will be teaching

Fill in the blanks by using future perfect tense :

He _____ his lesson by the evening.

Ans. (iii) will have learnt

B. Change the following sentences into simple past and simple future tense :

1. Kamal writes a letter.

Ans. • **Past:** Kamal wrote a letter.
• **Future:** Kamal will write a letter.

2. Does he sing a song ?

Ans. • **Past:** Did he sing a song?
• **Future:** Will he sing a song?

3. He does not tell a story.

Ans. • **Past:** He did not tell a story.
• **Future:** He will not tell a story.

4. Deepak weeps.

Ans. • **Past:** Deepak wept.
• **Future:** Deepak will weep.

C. Change the following sentence into past continuous and future continuous tense :

1. He is writing a novel.

- Ans.**
- **Past continuous:** He was writing a novel.
 - **Future continuous:** He will be writing a novel.

2. I wrote a story.

- Ans.**
- **Past continuous:** I was writing a story.
 - **Future continuous:** I will be writing a story.

3. Raj will teach you.

- Ans.**
- **Past continuous:** Raj was teaching you.
 - **Future continuous:** Raj will be teaching you.

4. She sings a song.

- Ans.**
- **Past continuous:** She was singing a song.
 - **Future continuous:** She will be singing a song.

5. She weeps.

- Ans.**
- **Past continuous:** She was weeping.
 - **Future continuous:** She will be weeping.

6. He told a story.

- Ans.**
- **Past continuous:** He was telling a story.
 - **Future continuous:** He will be telling a story.

D. Change the following sentences into present perfect and future perfect tense:

1. I am doing my work.

- Ans.**
- **Present perfect:** I have done my work.
 - **Future perfect:** I will have done my work.

2. He will fly a kite.

- Ans.**
- **Present perfect:** He has flown a kite.
 - **Future perfect:** He will have flown a kite.

3. He sings a song.

- Ans.**
- **Present perfect:** He has sung a song.
 - **Future perfect:** He will have sung a song.

4. She writes a letter.

- Ans.**
- **Present perfect:** She has written a letter.
 - **Future perfect:** She will have written a letter.

5. He will dance.

- Ans.**
- **Present perfect:** He has danced.
 - **Future perfect:** He will have danced.

6. She makes a noise.

- Ans.
- **Present perfect:** She has made a noise.
 - **Future perfect:** She will have made a noise.

E. **Fill in the blanks with the past perfect tense of the given in the brackets :**

1. Ekta and Priya **had gone** to the market.
2. He **had committed** a mistake.
3. I **had reached** the station before the train arrived.
4. The police **had arrested** him before he left the room.
5. I **had lost** my books.
6. The tailor **had sewn** the shirt before I reached his shop.
7. Vikas **had reached** the school before the bell rang.
8. She **had left** for Delhi before her husband came.
9. Aman **had done** his work in the morning.
10. I **had gone** to Meerut.

15

Prepositions

A. **Tick (✓) the right option :**

1. The preposition 'besides' means _____.

Ans. (ii) by the side of

2. Which Preposition is formed by adding prefix?

Ans. (iii) Compound Preposition

B. **Fill in the blanks with the suitable prepositions :**

1. He was born **in** February.
2. The dog was hidden **behind** a bush.
3. The fan is **on** the roof.
4. I went there **in** 2025.
5. Do not stop him **from** going there.
6. I was desirous **of** going to the fair.
7. We get up early **in** the morning.
8. Book was lying **on** the table.

C. **Use the given prepositions in your own sentences :**

1. into **The cat jumped into the box.**
2. outside **He is waiting outside the house.**
3. from **She came from Delhi yesterday.**
4. by **The letter was written by him.**

5. till **Wait here till I return.**
 6. since **She has been studying since morning.**
 7. up **He climbed up the hill.**

D. Answer the following questions :

1. Give some examples of Phrase Prepositions.

Ans. in place of, because of, in spite of, according to, in addition to

2. Give some examples of simple Prepositions.

Ans. at, in, on, by, for, with, from

16

Conjunctions

A. Tick (✓) the right option :

1. A conjunction joins _____ .

Ans. (iii) words, groups of words or sentences.

2. He lost his purse _____ he began to weep.

Ans. (iii) so

3. Dr. Roy is old _____ he is physically fit.

Ans. (iii) but

B. Underline the conjunctions in the following sentences:

1. Priya is intelligent but lazy.
2. You should wait here till your sister returns.
3. Kirti is clever but careless.
4. He is rich, still he is not happy
5. Sagar and Aman work hard.
6. You cannot pass unless you work hard.
7. Catch me if you can.
9. If Megha works hard, she will succeed.
10. Work hard, otherwise you will fail.
11. He ran fast, lest he should miss the period.
12. My neighbor is very honest although he is poor.

17

Punctuation and Capital Letters

A. Tick (✓) the right option :

1. A question mark is placed at the end of an _____ .

Ans. (ii) interrogative sentence

2. For showing possession, we use :

Ans. (iii) Apostrophe

3. The pronoun 'I' is always written in :

Ans. (i) Capital

B. Punctuate the following sentence :

1. when did you come from delhi

Ans. When did you come from Delhi?

2. The old man said hard work is the key to success

Ans. The old man said, "Hard work is the key to success."

3. mrs anjali knows english hindi french bengali tamil and punjabi

Ans. Mrs Anjali knows English, Hindi, French, Bengali, Tamil and Punjabi.

4. he killed a snake which was highly poisonous

Ans. He killed a snake, which was highly poisonous.

5. yes i can meet you tomorrow if the weather is fine

Ans. Yes, I can meet you tomorrow, if the weather is fine.

6. maharana pratap was in fact a very brave wise and patriot king

Ans. Maharana Pratap was, in fact, a very brave, wise and patriot king.

7. delhi the capital of india is also a city of historical interest

Ans. Delhi, the capital of India, is also a city of historical interest.

8. What is in your pocket

Ans. What is in your pocket?

9. he is an honest sincere and laborious boy

Ans. He is an honest, sincere and laborious boy.

10. Hurrah the exam is over

Ans. Hurrah! The exam is over.

C. Insert apostrophe (') wherever need :

- | | | | |
|-----------------|----------------------|--------------------|-------------------------|
| 1. kings crowns | kings' crowns | 2. Shirutis book | Shiruti's book |
| 3. Akshys suit | Akshy's suit | 4. cows tail | cow's tail |
| 5. Ektas purse | Ekta's purse | 6. mechanics tools | mechanics' tools |
| 7. Captains bat | Captain's bat | 8. chemists shops | chemists' shops |

D. Use capital letters and punctuation marks where necessary :

1. john was very kind he wanted to help the needy he put a lame man on the horse he himself walked behind the lame man was infact a dacoit suddenly he made the horse run john said you may take the horse but do not tell anyone this, otherwise no one will help the needy

Ans. John was very kind. He wanted to help the needy. He put a lame man on the horse. He himself walked behind the lame man. The man was, in fact, a dacoit. Suddenly, he made the horse run. John said, "You may take the horse, but do not tell anyone this, otherwise no one will help the needy."

2. the name of my pet dog is tommy he is a useful and faithful animal he guards our house at night he also plays with us

Ans. The name of my pet dog is Tommy. He is a useful and faithful animal. He guards our house at night. He also plays with us.

18

Direct and Indirect Speech

A. Tick (✓) the right option :

1. Indirect Speech the Reported speech begins with a :

Ans. (iii) capital letter

2. We do not give the exact words used by the speaker in :

Ans. (ii) Indirect Speech

3. The inverted commas are omitted in :

Ans. (ii) Indirect Speech

B. Change the following Direct Speech into Indirect Speech :

1. Nishant said, "I am tired."

Ans. Nishant said that he was tired.

2. Komal says, "It is important to save petrol."

Ans. Komal says that it is important to save petrol.

3. He said to me, "I will do it now."

Ans. He told me that he would do it then.

4. Sagar said, "I like sweets."

Ans. Sagar said that he liked sweets.

5. Renu said to me, "How is your father today"?

Ans. Renu asked me how my father was that day.

6. We said to him, "Do you go to the temple daily?"

Ans. We asked him whether he went to the temple daily.

7. She said to me, "Have you seen the lion?"

Ans. She asked me whether I had seen the lion.

8. Aarti said to her mother, "I need some money."

Ans. Aarti told her mother that she needed some money.

9. He said to me, "Which game do you like the most?"

Ans. He asked me which game I liked the most.

10. The teacher said to us, "Where have you lost your pen?"

Ans. The teacher asked us where we had lost our pen.

C. Change the following sentences into Direct Speech :

1. The young man wished that he were a bird.

Ans. The young man said, "I wish I were a bird."

2. Koyal told me what a smart dog you have.

Ans. Koyal said to me, "What a smart dog you have!"

3. The doctor advised the man to avoid spicy food.

Ans. The doctor said to the man, "Avoid spicy food."

4. She asked me where is he.

Ans. She said to me, "Where is he?"

5. Mother told us that the breakfast was ready.

Ans. Mother said to us, "The breakfast is ready."

6. Rohit said that he would come back soon.

Ans. Rohit said, "I would come back soon."

7. She said that she always gets up early.

Ans. She said, "I always get up early."

8. Kamal said that he was not feeling well.

Ans. Kamal said, "I am not feeling well."

D. Answer the following questions :

1. What do you mean by Direct and Indirect Speech?

Ans. ● **Direct Speech:** Direct Speech is when we write the exact words spoken by a person inside inverted commas.

● **Indirect Speech:** Indirect Speech is when we report the words of a person in our own words without using inverted commas.

2. Write some changes that are made in converting a sentence from Direct to Indirect Speech.

Ans. ● The following changes are made:

- Inverted commas are removed.
- Pronouns are changed according to the subject.
- Tense is changed (Present tense usually changes into Past tense).
- Words showing nearness change (e.g., here – there, this – that).
- Conjunctions like that, if, or whether are used.

19

Active and Passive Voice

A. Tick (✓) the right option :

1. There are _____ voices.

Ans. (iii) two

2. The active voice denotes that the subject is the _____.

Ans. (i) doer of the action

3. The passive voice denotes that the subject of the verb is the _____.

Ans. (i) doer of the action

B. Change the following sentences from the Active Voice to the Passive Voice :

1. My father love me.

I am loved by my father.

2. The cat killed a rat.

A rat was killed by the cat.

3. A child was picking flowers.

Flowers were being picked by a child.

4. Payal will fly a kite.

A kite will be flown by Payal.

5. Sapna was telling a story.

A story was being told by Sapna.

6. Kamal has done the work.

The work has been done by Kamal.

7. She will beat him.

He will be beaten by her.

8. He saw me.

I was seen by him.

9. The boys are flying kites.

Kites are being flown by the boys.

10. They welcomed the guests.

The guests were welcomed by them.

C. Change the voice :

1. Poems are written by her.

Ans. The guests were welcomed by them.

2. The match has been won by our team.

Ans. Our team has won the match.

3. You have to perform these experiments.

Ans. These experiments have to be performed by you.

4. Rules must be obeyed.

Ans. We must obey the rules.

5. English is taught by Mr. Jain.

Ans. Mr. Jain teaches English.

6. The dishes were washed by us.

Ans. We washed the dishes.

7. The sight enchanted us.

Ans. We were enchanted by the sight.

8. The Ganga is worshipped as a Goddess by most Indians.

Ans. Most Indians worship the Ganga as a Goddess.

9. All the grass has been eaten by the horse.

Ans. The horse has eaten all the grass.

10. I was always helped by you.

Ans. You always helped me.

20

Direct and Indirect Notice and Message Writing

- A. You lost your wristwatch while playing in the school field. Write a notice to be put up on the school notice board in 40-50 words.

Notice

M.G Public School, Noida

Date: 15 July 2025

Lost Wristwatch

I lost my wristwatch on 14 July during the lunch break in the school playground. It is a black strap watch with a round dial. Anyone who finds it will be rewarded with a treat in the canteen.

Please contact the undersigned.

Rohit

Class V

- B. Read the following telephonic conversation between Divya and Mr. Sethi. Write a message for Divya's mother in about thirty-five words :

Message

15 July 20XX

5:00 p.m.

Mummy,

Mr. Sethi from father's office called. He said that father has an urgent meeting, so he will be late today. There is no need to worry.

Divya

- C. An old friend of yours is in town. He calls you up and wishes to meet you at a shopping mall. You are alone at home, but you want to meet your friend, who will be returning to Dehradun the next day. You decide to leave a message for your mother. Write this message in not more than 40 words.

Message

15 July 20XX

4:30 p.m.

Mummy,

My friend Rahul is in town and has asked me to meet him at the shopping mall. I will be back by 7 p.m. Please don't worry.

Your son

21

Paragraph Writing

1. No Pain No Gain

No pain no gain means we cannot achieve success without hard work. If we want to do something big in life, we must work hard and face difficulties. A student has to study regularly to get good marks. A player practices daily to win games. Hard work always gives success in the end. So, we should never be afraid of hard work.

2. Necessity is the Mother of Invention

Necessity is the mother of invention means when we need something badly, we find ways to create it. Many inventions were made because people needed them. For example, the invention of the wheel and electricity helped humans a lot. When problems come, people think and find new ideas. So, need always leads to new inventions.

3. A Visit to a Historical Place

Last year, I visited a historical place with my family. We went to the Red Fort in Delhi. It is very big and beautiful. I saw old buildings and learned about history. The guide told us many interesting facts. I enjoyed the visit very much. It was a wonderful experience for me.

4. God Helps Those Who Help Themselves

God helps those who help themselves means we must work hard before expecting help. If we sit idle, no one will help us. A student who studies regularly gets good marks. Hardworking people always succeed in life. God supports those who try their best. So, we should always be active and hardworking.

22

Letter Writing

1. Write a letter to your father requesting him to buy you a watch.

Boys Hostel

D.A.V. Public School

Dehradun

March 27, 2025

My dear father,

I hope you are well. My exams are going on these days. I need a wristwatch to manage my time properly during exams and daily routine. It will help me to be punctual.

So, I request you to kindly buy me a good watch. I will use it carefully.

Please give my regards to Mother and love to Sagar.

Yours lovingly

Aman

2. Write a letter to your friend describing how you caught a thief.

23, Teacher Colony

Dehradun

March 27, 2025

My dear Rohan,

I hope you are fine. I want to share an exciting incident with you. Yesterday, I caught a thief in our neighbourhood.

At night, I heard some noise outside. When I looked out, I saw a man trying to steal a bicycle. I immediately shouted for help. The neighbors gathered quickly and we caught the thief. Later, we handed him over to the police.

It was a brave and thrilling experience for me.

Yours sincerely

Rahul

3. Write a letter to your friend congratulating him/her on his selection as the Captain of the school cricket team.

S-4/302

Gill Colony

Saharanpur

March 27, 20XX

Dear Mohit,

I am very happy to hear that you have been selected as the captain of your school cricket team.

Congratulations on your great achievement! You truly deserve this position because of your hard work and talent. I am proud of you.

I wish you all the best for your future matches.

Yours sincerely

Vikas

23 Essay Writing

1. Grow More Trees

Trees are very useful to us. They give us oxygen to breathe. They make the air fresh and pure. Without trees, life on earth is not possible.

Trees give us fruits, wood and shade. Birds live on trees. They also help in bringing rain. They keep the environment cool and pleasant.

Nowadays many trees are cut down for buildings and roads. This is very harmful for us. It causes pollution and global warming.

We should plant more and more trees. We should not cut them unnecessarily. Everyone must take care of trees to make our earth green and healthy.

2. My School Library

My school has a big library. It is neat and clean. There are many books in the library. Students go there to read books.

There are books on different subjects. We can find story books, newspapers and magazines also. The library is a quiet place.

Our librarian is very kind. He helps us in choosing good books. We must follow rules in the library and keep silence.

The library is very useful for students. It increases our knowledge. I like my school library very much.

3. A Railway Journey

Last summer, I went on a railway journey with my family. We went to visit our grandparents. It was a very exciting journey.

We reached the railway station early. The train arrived on time. We sat near the window and enjoyed the view outside.

We saw green fields, rivers and small villages. Vendors came selling tea and snacks. The journey was very comfortable and enjoyable.

At last, we reached our destination safely. My grandparents were happy to see us. I will always remember this railway journey.

4. A Picnic

Last Sunday, I went on a picnic with my friends. We went to a nearby park. It was a very beautiful place.

We carried food, games and music with us. We played games and sang songs. Everyone was very happy and excited.

We ate our lunch together under a tree. The weather was pleasant. We enjoyed nature and fresh air.

In the evening, we returned home happily. It was a wonderful day. I will never forget this picnic.

24 Comprehension Passages

A. Read the passage and answer the questions given below :

I. Answer the following questions:

1. Why was Rekha often punished?

Ans. Rekha was often punished because she came late to school.

2. Why was Rekha keen to appear for the examination?

Ans. Rekha was keen to appear for the examination to win the scholarship.

3. Why were her hopes shattered?

Ans. Her hopes were shattered because she was late and could not complete her paper.

II. Suggest a suitable title for the story.

Ans. Value of Punctuality

III. Find the words from the passage that mean:

1. to be in time **punctual** 2. finish **complete**

3. test **examination** 4. not on time **late**

B. Read the following passage carefully and answer the questions given below:

I Answer the following questions:

1. Who was Androcles?

Ans. Androcles was a slave.

2. Why did Androcles run away?

Ans. He ran away because his master treated him very badly.

3. Where did he live?

Ans. He lived in a cave.

4. Why did the lion not attack Androcles in the cave?

Ans. The lion did not attack him because Androcles helped him by removing the thorn.

II. Give the synonyms of the following words:

- | | | | |
|-------------|----------|---------------|---------|
| 1. slave | servant | 4. master | owner |
| 2. cave | den | 5. frightened | afraid |
| 3. soldiers | army men | 6. luck | fortune |

C. Read the following passage and answer the questions given below:

I. Complete the following statements:

1. Two things necessary to keep fit are eating well and doing a lot of physical activity.
2. We will become overweight if we overeat.
3. We should not watch too much TV.
4. We should drink plenty of water.

II. Answer the following questions :

1. What is the key to happiness?

Ans. The key to happiness is fitness.

2. Why do we need exercise properly?

Ans. We need exercise properly to remain fit and avoid becoming overweight.

III. Give opposites of the following words from the passage:

- | | | | |
|-----------|----------------|--------|-----------------|
| poor | <u>rich</u> | near | <u>far</u> |
| presence | <u>absence</u> | small | <u>big</u> |
| difficult | <u>easy</u> | mental | <u>physical</u> |
| wise | <u>foolish</u> | foe | <u>friend</u> |



Grammar **EXPRESS** and Composition

Key 6 to 8

Author by :
Aayush Sharma
Ma (English) M.E.D., Ph.D

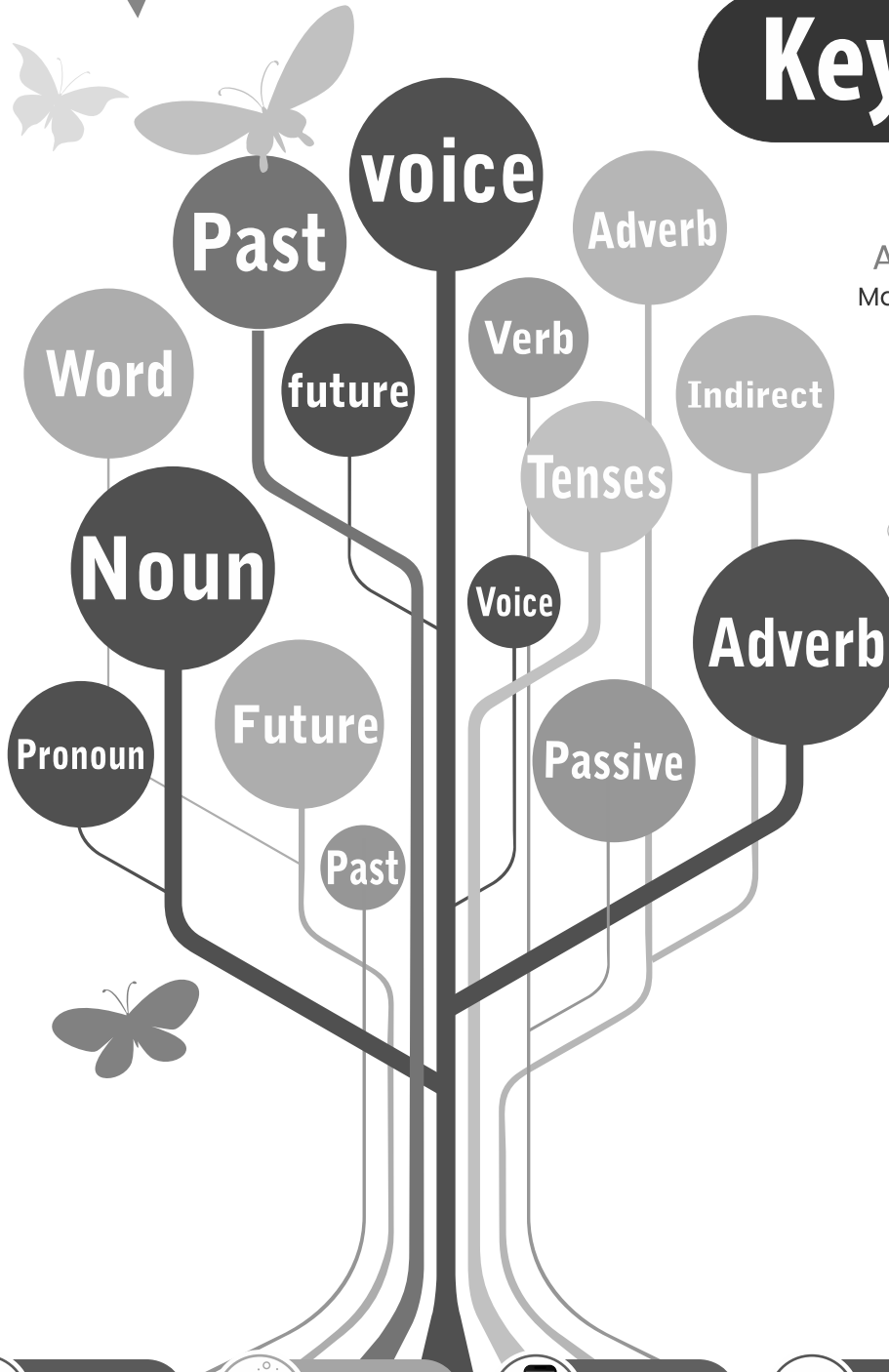

Test Paper
Generator



E-Teacher
Manual



Smart
Application



Web
Support

A. Name the kinds of sentences :

- | | |
|------------------------|---------------------------|
| 1. Assertive Sentence | 2. Interrogative Sentence |
| 3. Imperative Sentence | 4. Exclamatory Sentence |

B. Use the following words in your own sentences :

1. Assertive

- (a) Never : I never tell lies.
 (b) Diligently : She studies diligently every day.
 (c) Between : The ball is between the chairs.
 (d) Cannot : I cannot solve this problem.

2. Imperative

- (a) Run : Run fast to catch the bus.
 (b) Declare : Declare the result immediately.
 (c) Obey : Obey your parents.
 (d) Walk : Walk carefully on the road.

3. Interrogative

- (a) Did : Did you finish your homework?
 (b) Where : Where do you live?
 (c) Which : Which book is yours?
 (d) Have : Have you seen my bag?

C. Write the definition of :

1. Assertive : An assertive sentence is a sentence that states a fact, opinion, or statement and can be positive or negative.
 2. Imperative : An imperative sentence gives an order, command, request, advice, or suggestion.
 3. Interrogative : An interrogative sentence is used to ask a question.

D. Differentiate between :

1. Yes/No type questions and question word questions.

Yes/No Questions

Answered with yes or no

Example: Did you eat?

Question Word Questions

Need full answer/information

Example: Where do you live

2. Exclamatory sentences and Optative sentences :

Exclamatory Sentences

Express strong feelings (joy, surprise, etc.)

End with (!)

Example: What a beautiful day!

Optative Sentences

Express wish or prayer

Often begin with “May”

Example: May you succeed!

2

Subject and Predicate

A. In the following sentences separate the subject and the predicate :

1. The girl sat on a solid rock.

Ans. Subject: The girl

Predicate: sat on a solid rock

2. The chirping of the birds delights us.

Ans. Subject: The chirping of the birds

Predicate: delights us

3. Only walls do not make a home.

Ans. Subject: Only walls

Predicate: do not make a home

4. Nature is our mother.

Ans. Subject: Nature

Predicate: is our mother

5. Don't run on the road.

Ans. Subject: (You) (understood)

Predicate: Don't run on the road

6. Moscow is the capital of Russia.

Ans. Subject: Moscow

Predicate: is the capital of Russia

7. It is difficult to serve two masters.

Ans. Subject: It

Predicate: is difficult to serve two masters

8. His courage won him honour.

Ans. Subject: His courage

Predicate: won him honour

9. People who pay their debts are trusted.

Ans. **Subject:** People who pay their debts
Predicate: are trusted

10. The early bird catches the worm.

Ans. **Subject:** The early bird
Predicate: catches the worm

11. All roads lead to Rome.

Ans. **Subject:** All roads
Predicate: lead to Rome

12. He has a good memory.

Ans. **Subject:** He
Predicate: has a good memory

3

The Phrases and The Clauses

A. Replace the adjectives with adjective phrases as shown in the first sentence :

1. He is a meritorious student.

Ans. He is a student of great merit.

2. The lion is a strong animal.

Ans. The lion is an animal of great strength.

3. He is a courageous man.

Ans. He is a man of great courage.

4. Kolkata is a thickly populated town.

Ans. Kolkata is a town with a thick population.

5. This is an important matter.

Ans. This is a matter of great importance.

6. Ravi is a sensible boy.

Ans. Ravi is a boy of good sense.

7. This is a golden ornament.

Ans. This is an ornament of gold.

8. He wore a blue shirt.

Ans. He wore a shirt of blue colour.

B. Replace adverbs with adverb phrases as shown in the first sentence :

1. He listened to me attentively.

Ans. He listened to me with attention.

2. She sang a song beautifully.

Ans. She sang a song with beauty.

3. The principal is calling you immediately.

Ans. The principal is calling you at once.

4. He had gone hurriedly.

Ans. He had gone in a hurry.

5. Fortunately he succeeded this time.

Ans. By good fortune, he succeeded this time.

6. The man escaped industriously.

Ans. The man escaped with industry.

7. The soldiers fought mysteriously.

Ans. The soldiers fought in a mysterious manner.

8. Read your books carefully.

Ans. Read your books with care.

C. Replace the adjectives and the adjectives phrases in the following sentences with adverb clause as shown in the first sentence :

1. This is an interesting book.

Ans. This is the book which is interesting.

2. An old man walked in the street.

Ans. An old man walked in the street → A man who was old walked in the street.

3. We still remember those happy days.

Ans. We still remember those days which were happy.

4. Sita studies in a beautiful school.

Ans. Sita studies in a school which is beautiful.

5. Delhi is a bigger town than Dehradun.

Ans. Delhi is a town which is bigger than Dehradun.

6. We have passed a busy day today.

Ans. We have passed a day which was busy today.

7. Anil is a mischievous boy.

Ans. Anil is a boy who is mischievous.

8. He has a loud voice.

Ans. He has a voice which is loud.

9. The laborious boy stood first.

Ans. The boy who was laborious stood first.

10. Mohan is a violet-natured boy.

Ans. Mohan is a boy who has a violet nature.

4

Noun

Choose nouns from the following sentences and write their kinds in the given space :

| | Kind | Noun |
|---|----------|-------------------|
| 1. They live on an island. | island | – Common Noun |
| 2. Is this train leaving now? | train | – Common Noun |
| 3. It usually goes to Ranchi. | Ranchi | – Proper Noun |
| 4. Heroic deeds deserve to be admired. | deeds | – Common Noun |
| 5. A grey cloud spread overhead. | cloud | – Common Noun |
| 6. He dwelt in a wooden hut. | hut | – Common Noun |
| 7. She wore a diamond necklace. | diamond | – Material Noun |
| | necklace | – Common Noun |
| 8. It was a horrible sight. | sight | – Abstract Noun |
| 9. She is a famous dancer. | dancer | – Common Noun |
| 10. The leaders should learn to govern. | leaders | – Common Noun |
| 11. He gave me a bunch of grapes. | bunch | – Collective Noun |
| | grapes | – Common Noun |
| 12. Never tell a lie. | lie | – Abstract Noun |
| 13. We all love honesty. | honesty | – Abstract Noun |
| 14. The crowd was very big. | crowd | – Collective Noun |
| 15. Always speak the truth. | truth | – Abstract Noun |

5

The Noun : Number

A. Fill in the blanks with singular or plural form of the nouns :

1. The cat is the sitting on my bed.
2. There are five books on my desk .
3. They are riding their bikes.
4. How many books do you have ?
5. There are three windows in the room.

B. Transform the following singular nouns into plural :

- | | | | |
|--------------|-------------------------|--------------|-----------------------|
| 1. door | <u>doors</u> | 2. pony | ponies |
| 3. copy | copies | 4. sepoy | sepoys |
| 5. story | stories | 6. toy | toys |
| 7. grass | grasses | 8. echo | echoes |
| 9. crutch | crutches | 10. hero | heroes |
| 10. momento | momentos | 12. commando | commandos |
| 13. dynamo | dynamos | 14. knife | knives |
| 15. radius | radii / radiuses | 16. belief | beliefs |
| 17. photo | photos | 18. torch | torches |
| 19. mosquito | mosquitoes | 20. focus | foci / focuses |

C. Transform the following plural nouns into singular :

- | | | | |
|--------|------------|---------|-----------|
| 1. men | man | 2. oxen | ox |
|--------|------------|---------|-----------|

3. ladies **lady**

4. cities **city**

5. leaves **leaf**

6. feet **foot**

7. dwarfs **dwarf**

8. wolves **wolf**

9. mice **mouse**

10. geese **goose**

6

The Noun : Gender

Rewrite the following sentences changing the masculine gender words into feminine gender :

1. The tiger upon the king but he killed it.

Ans. The tigress upon the queen but she killed it.

2. The dog bit the son of a milkman.

Ans. The bitch bit the daughter of a milkmaid.

3. The Czar of Russia met the Sultan of Arab.

Ans. The Czarina of Russia met the Sultana of Arabia.

4. The old man blessed the bride-groom.

Ans. The old woman blessed the bride.

5. The actor played the part of a hunter in the film.

Ans. The actress played the part of a huntress in the film.

6. The heir to the throne was the prince who bowed before his father.

Ans. The heiress to the throne was the princess who bowed before her mother.

7. The author wrote his first book when he was only seven years old.

Ans. The authoress wrote her first book when she was only seven years old.

8. His nephews and brothers danced together.

Ans. His nieces and sisters danced together.

9. His son rides on the white horse.

Ans. His daughter rides on the white mare.

10. His uncle was a man-servant who came with a cock and a peacock.

Ans. His aunt was a maid-servant who came with a hen and a peahen.

7

The Noun : Case

Write the possessive case of the following :

- | | |
|--------------------------------------|------------------------------|
| 1. The leave for a day. | A day's leave |
| 2. The shop of Govind. | Govind's shop |
| 3. The house of landlord. | The landlord's house |
| 4. The list of students. | The students' list |
| 5. The hostel of the boys. | The boys' hostel |
| 6. The ornaments of the women. | The women's ornaments |
| 7. The cries of children. | The children's cries |
| 8. The street named after Gandhiji. | Gandhiji's street |
| 9. The apparels of men. | Men's apparels |
| 10. The chiding of the master. | The master's chiding |
| 11. The temple built by Ramesh. | Ramesh's temple |
| 12. The love felt by a mother. | A mother's love |
| 13. The plays written by Shakespear. | Shakespeare's plays |
| 14. The temple dedicated to Rama. | Rama's temple |

8

Pronouns

A. Join the following sentences by using relative pronouns:

1. I know a boy. He has passed matric.

Ans. I know a boy who has passed matric.

2. The beggar hit the dog. The dog bit him.

Ans. The beggar hit the dog which bit him.

3. Show me the road. The road leads to Mumbai.

Ans. Show me the road which leads to Mumbai.

4. I met a soldier. He was very kind.

Ans. I met a soldier who was very kind.

5. The man is honest. The man is trusted.

Ans. The man who is honest is trusted.

6. The teacher punished the boy. The boy cried.

Ans. The teacher punished the boy who cried.

7. We met a child. The child had lost its way.

Ans. We met a child who had lost its way.

8. Gandhiji was famous. Gandhiji fought for our freedom.

Ans. Gandhiji who fought for our freedom was famous.

9. He is a rogue. No one trusts him.

Ans. He is a rogue whom no one trusts.

10. Oil is found in Assam. It is a useful mineral.

Ans. Oil which is found in Assam is a useful mineral.

B. What is the difference between a reflexive pronoun and a emphatic pronoun?

Ans. Reflexive Pronoun: A reflexive pronoun is used when the subject and the object of the sentence are the same. It shows that the action done by the subject comes back to the subject itself.

Example: He hurt himself.

Emphatic Pronoun: An emphatic pronoun is used to emphasize (stress) a noun or pronoun. It does not affect the meaning of the sentence but adds emphasis.

Example: He himself completed the work.

C. Turn the following nominative case pronoun into possessive and objective case:

| Nominative Case | Possessive Case | Objective Case |
|-----------------|-----------------|----------------|
| He | his | him |
| She | her | her |
| It | its | it |
| You | your | you |
| We | our | us |
| It | its | it |

D. Correct the following sentences :

1. Mrs. Rajni is strict. I don't like her.
Mrs. Rajni is strict. I don't like her.
2. Anu isn't good at math. I never copy from she.
Anu isn't good at math. I never copy from her.
3. We have a computer at home, but I don't use him.
We have a computer at home, but I don't use it.
4. My teachers are very good. I don't like they.
My teachers are very good. I don't like them.

E. Complete the following sentences with correct personal pronouns :

1. I am standing on my head. Look at me.
2. My mother is very kind. Every body likes her.
3. I have a dog which is called lucky.
4. My family and I live in a city.



Adjectives

A. Make sentences of your own words using the following adjectives:

1. narrow : This is a narrow road.
2. courageous : The soldier is very courageous.
3. long : She has long hair.
4. beautiful : The garden is beautiful.

5. polite : **He is a polite boy.**
6. many : **There are many books on the table.**
7. three : **I have three pencils.**
8. these : **These apples are fresh.**
9. wild : **The tiger is a wild animal.**
10. experienced : **He is an experienced teacher.**

B. Write adjectives (opposite in meaning) to the following adjectives:

- | | | | |
|-------------|----------------------------|----------------|-------------------|
| 1. active | inactive | 2. beautiful | ugly |
| 3. healthy | unhealthy | 4. slow | fast |
| 5. dull | bright | 6. friendly | unfriendly |
| 7. cruel | kind | 8. black | white |
| 9. decisive | indecisive | 10. hot | cold |
| 11. devoted | careless / disloyal | 12. whole | half |
| 13. clean | dirty | 14. tired | fresh |
| 15. many | few | 16. lovable | hateful |
| 17. heavy | light | 18. dependable | unreliable |
| 19. good | bad | 20. careful | careless |

C. Write suitable adjectives to the following nouns:

- | | | | |
|-------------|----------------------|----------|-------------------------|
| 1. boy | smart boy | 2. hand | clean hand |
| 3. child | happy child | 4. clock | big clock |
| 5. tree | tall tree | 6. pen | blue pen |
| 7. mountain | high mountain | 8. storm | strong storm |
| 9. water | clean water | 10. book | interesting book |
| 11. king | brave king | 12. hope | great hope |
| 13. dog | faithful dog | 14. salt | salty salt |

- | | | | |
|------------|----------------------|-----------|-----------------------|
| 15. beggar | poor beggar | 16. sheep | white sheep |
| 17. lady | kind lady | 18. gift | beautiful gift |
| 19. singer | famous singer | 20. girl | pretty girl |

D. Form adjectives from the following verbs and nouns:

- | | | | |
|-------------|--------------------|-------------|-------------------|
| 1. boy | boyish | 2. to talk | talkative |
| 3. trouble | troublesome | 4. man | manly |
| 5. envy | envious | 6. king | kingly |
| 7. gold | golden | 8. gift | gifted |
| 9. to cease | ceaseless | 10. pardon | pardonable |
| 11. to move | movable | 12. respect | respectful |

10 Verbs

Underline verbs in the following sentences and tell whether they are transitive, intransitive or linking verbs:

- | | |
|--|--------------------------|
| 1. The dog <u>barks</u> at the beggar. | Intransitive Verb |
| 2. The remover <u>seems</u> fine. | Linking Verb |
| 3. Good boys <u>tell</u> the truth. | Transitive Verb |
| 4. The wind <u>blew</u> hard. | Intransitive Verb |
| 5. He <u>acted</u> his part well. | Transitive Verb |
| 6. Sushama <u>sang</u> sweetly. | Intransitive Verb |
| 7. The bridge has <u>grown</u> old. | Linking Verb |
| 8. He has <u>grown</u> old. | Linking Verb |

11 Three Forms of Verbs

Write the past and past participle forms of the following verbs:

| Present | Past | Past Participle |
|---------|--------|-----------------|
| 1 abuse | abused | abused |

| | | | |
|----|------------|------------|------------|
| 2 | agree | agreed | agreed |
| 3 | beg | begged | begged |
| 4 | bring | brought | brought |
| 5 | call | called | called |
| 6 | creep | crept | crept |
| 7 | deal | dealt | dealt |
| 8 | feed | fed | fed |
| 9 | fulfil | fulfilled | fulfilled |
| 10 | buy | bought | bought |
| 11 | cry | cried | cried |
| 12 | excuse | excused | excused |
| 13 | free | freed | freed |
| 14 | keep | kept | kept |
| 15 | make | made | made |
| 16 | seek | sought | sought |
| 17 | spend | spent | spent |
| 18 | turn | turned | turned |
| 19 | behold | beheld | beheld |
| 20 | know | knew | known |
| 21 | allow | allowed | allowed |
| 22 | bring | brought | brought |
| 23 | creep | crept | crept |
| 24 | follow | followed | followed |
| 25 | sleep | slept | slept |
| 26 | understand | understood | understood |
| 27 | beset | beset | beset |
| 28 | shed | shed | shed |
| 29 | prepare | prepared | prepared |
| 30 | join | joined | joined |
| 31 | glow | glowed | glowed |
| 32 | forget | forgot | forgotten |

Exercise

A. Transform the following affirmative sentences into negative and interrogative sentences:

Affirmative Sentences

1. The child drinks milk.

Ans. ➤ **Negative:** The child does not drink milk.

➤ **Interrogative:** Does the child drink milk?

2. He speaks English fluently.

Ans. ➤ **Negative:** He does not speak English fluently.

➤ **Interrogative:** Does he speak English fluently?

3. The girl wears frock.

Ans. ➤ **Negative:** The girl does not wear frock.

➤ **Interrogative:** Does the girl wear frock?

4. The insects sting hard.

Ans. ➤ **Negative:** The insects do not sting hard.

➤ **Interrogative:** Do the insects sting hard?

5. He chose grey colour.

Ans. ➤ **Negative:** He did not choose grey colour.

➤ **Interrogative:** Did he choose grey colour?

6. She came by train.

Ans. ➤ **Negative:** She did not come by train.

➤ **Interrogative:** Did she come by train?

7. The dog bit the boy.

Ans. ➤ **Negative:** The dog did not bite the boy.

➤ **Interrogative:** Did the dog bite the boy?

8. You wrote an essay.

Ans. ➤ **Negative:** You did not write an essay.

➤ **Interrogative:** Did you write an essay?

9. They told a lie.

Ans. ➤ **Negative:** They did not tell a lie.

➤ **Interrogative:** Did they tell a lie?

10. The player was tired.

Ans. ➤ **Negative:** The player was not tired.

➤ **Interrogative:** Was the player tired?

B. Transform the following sentences into Past and Future indefinite tense :

1. The peon rings the bell.

Ans. ➤ **Past:** The peon rang the bell.

➤ **Future:** The peon will ring the bell.

2. He shakes my hand.

Ans. ➤ **Past:** He shook my hand.

➤ **Future:** He will shake my hand.

3. They eat pizzas.

Ans. ➤ **Past:** They ate pizzas.

➤ **Future:** They will eat pizzas.

4. You do not sense things.

Ans. ➤ **Past:** You did not sense things.

➤ **Future:** You will not sense things.

5. The girl shows her toy.

Ans. ➤ **Past:** The girl showed her toy.

➤ **Future:** The girl will show her toy.

6. His voice sinks deep.

Ans. ➤ **Past:** His voice sank deep.

➤ **Future:** His voice will sink deep.

7. I tread the path alone.

Ans. ➤ **Past:** I trod the path alone.

➤ **Future:** I will tread the path alone.

8. The sun rises in the East.

Ans. ➤ **Past:** The sun rose in the East.
➤ **Future:** The sun will rise in the East.

9. It rains cats and dogs.

Ans. ➤ **Past:** It rained cats and dogs.
➤ **Future:** It will rain cats and dogs.

10. Does she go to bed early?

Ans. ➤ **Past:** Did she go to bed early?
➤ **Future:** Will she go to bed early?

11. Do they get a lot of home work?

Ans. ➤ **Past:** Did they get a lot of homework?
➤ **Future:** Will they get a lot of homework?

12. Do you meet a beautiful girl?

Ans. ➤ **Past:** Did you meet a beautiful girl?
➤ **Future:** Will you meet a beautiful girl?

13. The old man mistakes me for his son.

Ans. ➤ **Past:** The old man mistook me for his son.
➤ **Future:** The old man will mistake me for his son.

14. The batsman springs on his feet.

Ans. ➤ **Past:** The batsman sprang on his feet.
➤ **Future:** The batsman will spring on his feet.

Exercise

A. Transform the following Affirmative sentences into Negative and Interrogative sentences:

1. Rohit is selling goods.

Ans. ➤ **Negative:** Rohit is not selling goods.
➤ **Interrogative:** Is Rohit selling goods?

2. She is sleeping.

Ans. ➤ **Negative:** She is not sleeping.
➤ **Interrogative:** Is she sleeping?

3. He is binding books.

Ans. ➤ **Negative:** He is not binding books.

➤ **Interrogative:** Is he binding books?

4. The boy is breaking toys.

Ans. ➤ **Negative:** The boy is not breaking toys.

➤ **Interrogative:** Is the boy breaking toys?

5. She was crying bitterly.

Ans. ➤ **Negative:** She was not crying bitterly.

➤ **Interrogative:** Was she crying bitterly?

6. She was crying loudly.

Ans. ➤ **Negative:** She was not crying loudly.

➤ **Interrogative:** Was she crying loudly?

7. We were watching a movie.

Ans. ➤ **Negative:** We were not watching a movie.

➤ **Interrogative:** Were we watching a movie?

8. We shall be swearing by God.

Ans. ➤ **Negative:** We shall not be swearing by God.

➤ **Interrogative:** Shall we be swearing by God?

9. They were day-dreaming.

Ans. ➤ **Negative:** They were not day-dreaming.

➤ **Interrogative:** Were they day-dreaming?

10. I shall be buying a chocolate.

Ans. ➤ **Negative:** I shall not be buying a chocolate.

➤ **Interrogative:** Shall I be buying a chocolate?

B. Transform the following Present Continuous Tense sentences into Past and Future Continuous Sentences:

01. She is playing a guitar.

Ans. ➤ **Past:** She was playing a guitar.

➤ **Future:** She will be playing a guitar.

02. I am looking into it.

Ans. ➤ **Past:** I was looking into it.

➤ **Future:** I will be looking into it.

03. Is he assuring you?

Ans. ➤ **Past:** Was he assuring you?

➤ **Future:** Will he be assuring you?

04. Is the beggar begging?

Ans. ➤ **Past:** Was the beggar begging?

➤ **Future:** Will the beggar be begging?

05. Are they betraying us?

Ans. ➤ **Past:** Were they betraying us?

➤ **Future:** Will they be betraying us?

06. Are you buying a television?

Ans. ➤ **Past:** Were you buying a television?

➤ **Future:** Will you be buying a television?

07. Is the tiger bleeding?

Ans. ➤ **Past:** Was the tiger bleeding?

➤ **Future:** Will the tiger be bleeding?

08. Is the fire burning?

Ans. ➤ **Past:** Was the fire burning?

➤ **Future:** Will the fire be burning?

09. The bird is flying fast.

Ans. ➤ **Past:** The bird was flying fast.

➤ **Future:** The bird will be flying fast.

10. The water is overflowing the tank.

Ans. ➤ **Past:** The water was overflowing the tank.

➤ **Future:** The water will be overflowing the tank.

11. The president is addressing the session.

Ans. ➤ **Past:** The president was addressing the session.

➤ **Future:** The president will be addressing the session.

12. You are agreeing on this point.

Ans. ➤ **Past:** You were agreeing on this point.

➤ **Future:** You will be agreeing on this point.

13. We are not annoying you.

Ans. ➤ **Past:** We were not annoying you.

➤ **Future:** We will not be annoying you.

14. The plants are growing fast.

Ans. ➤ **Past:** The plants were growing fast.

➤ **Future:** The plants will be growing fast.

15. My sister is teaching me.

Ans. ➤ **Past:** My sister was teaching me.

➤ **Future:** My sister will be teaching me.

Exercise

A. Transform the following sentences into Negative and Interrogative sentences:

1. I have taken my breakfast.

Ans. ➤ **Negative:** I have not taken my breakfast.

➤ **Interrogative:** Have I taken my breakfast?

2. He has bent the branch.

Ans. ➤ **Negative:** He has not bent the branch.

➤ **Interrogative:** Has he bent the branch?

3. They have called you names.

Ans. ➤ **Negative:** They have not called you names.

➤ **Interrogative:** Have they called you names?

4. The police has caught the robbers.

Ans. ➤ **Negative:** The police has not caught the robbers.

➤ **Interrogative:** Has the police caught the robbers?

5. The soldiers have crept behind the rocks.

Ans. ➤ **Negative:** The soldiers have not crept behind the rocks.

➤ **Interrogative:** Have the soldiers crept behind the rocks?

6. The officer has severely dealt with him.

- Ans.** ➤ **Negative:** The officer has not severely dealt with him.
 ➤ **Interrogative:** Has the officer severely dealt with him?
7. The artillery fire has destroyed the fortification.
- Ans.** ➤ **Negative:** The artillery fire has not destroyed the fortification.
 ➤ **Interrogative:** Has the artillery fire destroyed the fortification?
8. Laxman has denied charges of bribery.
- Ans.** ➤ **Negative:** Laxman has not denied charges of bribery.
 ➤ **Interrogative:** Has Laxman denied charges of bribery?
9. The thief was set free after the police had arrived.
- Ans.** ➤ **Negative:** The thief was not set free after the police had arrived.
 ➤ **Interrogative:** Was the thief set free after the police had arrived?
10. I had fled the scene before Rekha came.
- Ans.** ➤ **Negative:** I had not fled the scene before Rekha came.
 ➤ **Interrogative:** Had I fled the scene before Rekha came?
11. I had fulfilled his desire even before he said it.
- Ans.** ➤ **Negative:** I had not fulfilled his desire even before he said it.
 ➤ **Interrogative:** Had I fulfilled his desire even before he said it?
12. The guest will have hoisted the flag.
- Ans.** ➤ **Negative:** The guest will not have hoisted the flag.
 ➤ **Interrogative:** Will the guest have hoisted the flag?
13. The chairman will have hosted a party.
- Ans.** ➤ **Negative:** The chairman will not have hosted a party.
 ➤ **Interrogative:** Will the chairman have hosted a party?
14. The process will have halted the proceedings.
- Ans.** ➤ **Negative:** The process will not have halted the proceedings.
 ➤ **Interrogative:** Will the process have halted the proceedings?
15. The tiger will have wounded the hunter.
- Ans.** ➤ **Negative:** The tiger will not have wounded the hunter.
 ➤ **Interrogative:** Will the tiger have wounded the hunter?
16. We shall have joined the team at Paris.

- Ans.** ➤ **Negative:** We shall not have joined the team at Paris.
➤ **Interrogative:** Shall we have joined the team at Paris?

B. Transform the following sentences into past and future perfect tense sentences:

1. I have kept it somewhere.

- Ans.** ➤ **Past Perfect:** I had kept it somewhere.
➤ **Future Perfect:** I will have kept it somewhere.

2. The priest has knelt down before the idol.

- Ans.** ➤ **Past Perfect:** The priest had knelt down before the idol.
➤ **Future Perfect:** The priest will have knelt down before the idol.

3. The leader has led the people effectively.

- Ans.** ➤ **Past Perfect:** The leader had led the people effectively.
➤ **Future Perfect:** The leader will have led the people effectively.

4. The students have laughed at the clown.

- Ans.** ➤ **Past Perfect:** The students had laughed at the clown.
➤ **Future Perfect:** The students will have laughed at the clown.

5. She has grinned from ear to ear.

- Ans.** ➤ **Past Perfect:** She had grinned from ear to ear.
➤ **Future Perfect:** She will have grinned from ear to ear.

6. We have learnt by our experience.

- Ans.** ➤ **Past Perfect:** We had learnt by our experience.
➤ **Future Perfect:** We will have learnt by our experience.

7. You have lost what you gained.

- Ans.** ➤ **Past Perfect:** You had lost what you gained.
➤ **Future Perfect:** You will have lost what you gained.

8. The cow has not lowed loudly.

- Ans.** ➤ **Past Perfect:** The cow had not lowed loudly.
➤ **Future Perfect:** The cow will not have lowed loudly.

9. They have not made a mistake.

- Ans.** ➤ **Past Perfect:** They had not made a mistake.

➤ **Future Perfect:** They will not have made a mistake.

10. She has not met with an accident.

Ans. ➤ **Past Perfect:** She had not met with an accident.

➤ **Future Perfect:** She will not have met with an accident.

11. The lender has not paid back as yet.

Ans. ➤ **Past Perfect:** The lender had not paid back as yet.

➤ **Future Perfect:** The lender will not have paid back as yet.

12. You have not preached what you did.

Ans. ➤ **Past Perfect:** You had not preached what you did.

➤ **Future Perfect:** You will not have preached what you did.

13. Has the teacher taught the lesson.

Ans. ➤ **Past Perfect:** Had the teacher taught the lesson?

➤ **Future Perfect:** Will the teacher have taught the lesson?

14. Has the government sought any aid?

Ans. ➤ **Past Perfect:** Had the government sought any aid?

➤ **Future Perfect:** Will the government have sought any aid?

15. Who has sent this parcel?

Ans. ➤ **Past Perfect:** Who had sent this parcel?

➤ **Future Perfect:** Who will have sent this parcel?

Exercise

A. Transform the following sentences into Negative and Interrogative sentences:

1. The canons have been bursting for half an hour.

Ans. ➤ **Negative:** The cannons have not been bursting for half an hour.

➤ **Interrogative:** Have the cannons been bursting for half an hour?

2. People have been casting coins into rivers for ages.

Ans. ➤ **Negative:** People have not been casting coins into rivers for ages.

➤ **Interrogative:** Have people been casting coins into rivers for ages?

3. Radha has been cutting vegetables for two hours.

Ans. ➤ **Negative:** Radha has not been cutting vegetables for two hours.

➤ **Interrogative:** Has Radha been cutting vegetables for two hours?

4. The doorkeeper has been letting us in since last year.

- Ans.** ➤ **Negative:** The doorkeeper has not been letting us in since last year.
 ➤ **Interrogative:** Has the doorkeeper been letting us in since last year?

5. She had been abiding by law since her birth.

- Ans.** ➤ **Negative:** She had not been abiding by law since her birth.
 ➤ **Interrogative:** Had she been abiding by law since her birth?

6. They had been bearing the brunt since last week.

- Ans.** ➤ **Negative:** They had not been bearing the brunt since last week.
 ➤ **Interrogative:** Had they been bearing the brunt since last week?

7. The girl had been knitting since morning.

- Ans.** ➤ **Negative:** The girl had not been knitting since morning.
 ➤ **Interrogative:** Had the girl been knitting since morning?

8. The wind had been blowing hard for two hours.

- Ans.** ➤ **Negative:** The wind had not been blowing hard for two hours.
 ➤ **Interrogative:** Had the wind been blowing hard for two hours?

9. The women will have been choosing colours since Sunday.

- Ans.** ➤ **Negative:** The women will not have been choosing colours since Sunday.
 ➤ **Interrogative:** Will the women have been choosing colours since Sunday?

10. I shall have been driving the bus for three years.

- Ans.** ➤ **Negative:** I shall not have been driving the bus for three years.
 ➤ **Interrogative:** Shall I have been driving the bus for three years?

11. We shall have been drinking wine for ten minutes.

- Ans.** ➤ **Negative:** We shall not have been drinking wine for ten minutes.
 ➤ **Interrogative:** Shall we have been drinking wine for ten minutes?

12. You will have been eating fruits since evening.

- Ans.** ➤ **Negative:** You will not have been eating fruits since evening.
 ➤ **Interrogative:** Will you have been eating fruits since evening?

13. Leaves will have been falling since autumn.

- Ans.** ➤ **Negative:** Leaves will not have been falling since autumn.
 ➤ **Interrogative:** Will leaves have been falling since autumn?

14. The crocodile has been shedding tears for fifteen minutes.

- Ans.** ➤ **Negative:** The crocodile has not been shedding tears for fifteen minutes.
➤ **Interrogative:** Has the crocodile been shedding tears for fifteen minutes?

15. The farmer has been splitting bamboos since 9:00 o'clock.

- Ans.** ➤ **Negative:** The farmer has not been splitting bamboos since 9:00 o'clock.
➤ **Interrogative:** Has the farmer been splitting bamboos since 9:00 o'clock?

B. Transform the following sentences into past and future perfect continuous tense :

1. He has been flinging the ball for two hours.

- Ans.** ➤ **Past:** He had been flinging the ball for two hours.
➤ **Future:** He will have been flinging the ball for two hours.

2. She has been flying an aeroplane for forty minutes.

- Ans.** ➤ **Past:** She had been flying an aeroplane for forty minutes.
➤ **Future:** She will have been flying an aeroplane for forty minutes.

3. The refrigerator has been freezing ice since we bought it.

- Ans.** ➤ **Past:** The refrigerator had been freezing ice since we bought it.
➤ **Future:** The refrigerator will have been freezing ice since we bought it.

4. He has been getting pension ever since he retired.

- Ans.** ➤ **Past:** He had been getting pension ever since he retired.
➤ **Future:** He will have been getting pension ever since he retired.

5. Her mother has been grinding wheat for ten years.

- Ans.** ➤ **Past:** Her mother had been grinding wheat for ten years.
➤ **Future:** Her mother will have been grinding wheat for ten years.

6. We have been holding on to our position for three years.

- Ans.** ➤ **Past:** We had been holding on to our position for three years.
➤ **Future:** We will have been holding on to our position for three years.

7. The sun has not been rising in the evening for ages.

- Ans.** ➤ **Past:** The sun had not been rising in the evening for ages.
➤ **Future:** The sun will not have been rising in the evening for ages.

8. He has not been rising slowly for two weeks.

- Ans.** ➤ **Past:** He had not been rising slowly for two weeks.
➤ **Future:** He will not have been rising slowly for two weeks.

9. The moon has not been shining since yesterday.

- Ans.** ➤ **Past:** The moon had not been shining since yesterday.
 ➤ **Future:** The moon will not have been shining since yesterday.

10. The poet has not been writing poetry since childhood.

- Ans.** ➤ **Past:** The poet had not been writing poetry since childhood.
 ➤ **Future:** The poet will not have been writing poetry since childhood.

11. He has been speaking English since Tuesday.

- Ans.** ➤ **Past:** He had been speaking English since Tuesday.
 ➤ **Future:** He will have been speaking English since Tuesday.

12. Have the bees been stinging the passers-by for half an hour?

- Ans.** ➤ **Past:** Had the bees been stinging the passers-by for half an hour?
 ➤ **Future:** Will the bees have been stinging the passers-by for half an hour?

13. Has the farmer been working hard for two months?

- Ans.** ➤ **Past:** Had the farmer been working hard for two months?
 ➤ **Future:** Will the farmer have been working hard for two months?

14. Why has he been striving for success since 2024?

- Ans.** ➤ **Past:** Why had he been striving for success since 2024?
 ➤ **Future:** Why will he have been striving for success since 2024?

15. Have the ministers been taking the oath of office for one hour?

- Ans.** ➤ **Past:** Had the ministers been taking the oath of office for one hour?
 ➤ **Future:** Will the ministers have been taking the oath of office for one hour?

16. Has he been treading the path alone for five years?

- Ans.** ➤ **Past:** Had he been treading the path alone for five years?
 ➤ **Future:** Will he have been treading the path alone for five years?

17. How long has he been staying at the hotel?

- Ans.** ➤ **Past:** How long had he been staying at the hotel?
 ➤ **Future:** How long will he have been staying at the hotel?

18. Had the hockey players been playing cricket for two weeks?

- Ans.** ➤ **Past:** Had the hockey players been playing cricket for two weeks?
 ➤ **Future:** Will the hockey players have been playing cricket for two weeks?

19. Where have the children been tearing pages from books for two days?

- Ans.** ➤ **Past:** Where had the children been tearing pages from books for two days?
 ➤ **Future:** Where will the children have been tearing pages from books for two days?

13

Active and Passive Voice

Exercise

A. Transform the following sentences into the passive voice:

Active Voice

1. He walk five miles.
2. You paint the door red.
3. The peon rings the bell.
4. They cut vegetables.
5. We bet five rupees.
6. She bent a branch.
7. The bitch bred her pups.
8. You brought your friend.
9. They built a building.
10. We burnt wood.
11. They will buy wares.
12. The labourers will dig a pit.
13. Granny will feed her children.
14. Papa will love us.
15. The soldiers do not fight a war.
16. He does not get first division.
17. I do not hear a sound.
18. I did not hold her hand.
19. We did not learn our lesson.
20. I shall not lose my purse.
21. She will not light a lamp.
22. I shall not lose my book.
23. She will not mean it.
24. Do you meet her?
25. Does she pay him?
26. Do they run a race?
27. Does he say this?
28. Did you send him there?
29. Did they do this?
30. Did she spend money?
31. Will you spill milk?
31. Shall we spoil the show?

Passive Voice

- Five miles are walked by him.
The door is painted red by you.
The bell is rung by the peon.
Vegetables are cut by them.
Five rupees are bet by us.
A branch was bent by her.
Her pups were bred by the bitch.
Your friend was brought by you.
A building was built by them.
Wood was burnt by us.
Wares will be bought by them.
A pit will be dug by the labourers.
Her children will be fed by granny.
We shall be loved by papa.
A war is not fought by the soldiers.
First division is not got by him.
A sound is not heard by me.
Her hand was not held by me.
Our lesson was not learnt by us.
My purse shall not be lost by me.
A lamp will not be lighted by her.
My book shall not be lost by me.
It will not be meant by her.
Is she met by you?
Is he paid by her?
Is he paid by her?
Is this said by him?
Was he sent there by you?
Was this done by them?
Was money spent by her?
Will milk be spilt by you?
Will the show be spoilt by us?

Exercise

A. Transform the following sentences into the passive voice:

| Active Voice | Passive Voice |
|------------------------------------|---|
| 1. She is blowing whistles. | Whistles are being blown by her. |
| 2. He is biting a guava. | A guava is being bitten by him. |
| 3. They are breaking toys. | Toys are being broken by them. |
| 4. The captain is selecting me. | I am being selected by the captain. |
| 5. You were drinking wine. | Wine was being drunk by you. |
| 6. I was driving a car. | A car was being driven by me. |
| 7. She was eating pizzas. | Pizzas were being eaten by her. |
| 8. You were flying an aeroplane. | An aeroplane was being flown by you. |
| 9. He is not forgetting her name. | Her name is not being forgotten by him. |
| 10. The wind is not freezing us. | We are not being frozen by the wind. |
| 11. They were not telling a lie. | A lie was not being told by them. |
| 12. You were not riding a horse. | A horse was not being ridden by you. |
| 13. Are you watching television? | Is television being watched by you? |
| 14. Is mother sewing your clothes? | Are your clothes being sewn by mother? |
| 15. Why is he shaking me? | Why am I being shaken by him? |

Exercise

A. Transform the following sentences from the Active Voice to Passive Voice:

1. I have begged your pardon.

Ans. Your pardon has been begged by me.

2. You have betrayed our cause.

Ans. Our cause has been betrayed by you.

3. She had brought a beautiful frock.

Ans. A beautiful frock had been brought by her.

4. We had bought a refrigerator.

Ans. A refrigerator had been bought by us.

5. The fools had burnt the vehicle.

Ans. The vehicle had been burnt by the fools.

6. He had sought our help.

Ans. Our help had been sought by him.

7. The lioness had bred her cub.

Ans. Her cub had been bred by the lioness.

8. I shall have bent the rod.

Ans. The rod shall have been bent by me.

9. You will have invited me to tea.

Ans. I shall have been invited to tea by you.

10. The wind has not freed the clothes.

Ans. The clothes have not been freed by the wind.

11. We have not insured this scooter.

Ans. This scooter has not been insured by us.

12. The jailor has not freed the captive.

Ans. The captive has not been freed by the jailor.

13. You have not fed the poor.

Ans. The poor have not been fed by you.

14. She has not felt the pain.

Ans. The pain has not been felt by her.

15. The water had not flooded the river.

Ans. The river had not been flooded by the water.

16. He had not followed the rules.

Ans. The rules had not been followed by him.

17. They had not failed the examination.

Ans. The examination had not been failed by them.

18. You will not have hosted the party.

Ans. The party will not have been hosted by you.

19. We shall not have hoisted the flag.

Ans. The flag shall not have been hoisted by us.

20. They will not have helped us.

Ans. We will not have been helped by them.

21. How will they not have halted the train?

Ans. How will the train not have been halted by them?

22. The nurse hated the patient?

Ans. The patient was hated by the nurse.

23. Have you injured the dog?

Ans. Has the dog been injured by you?

24. Have you joined the party?

Ans. Has the party been joined by you?

25. Have they kept their word?

Ans. Has their word been kept by them?

26. Had we killed the insect?

Ans. Had the insect been killed by us?

27. Had the leader led the people?

Ans. Had the people been led by the leader?

28. Had the hen laid golden eggs?

Ans. Had golden eggs been laid by the hen?

29. Had he learnt any lesson?

Ans. Had any lesson been learnt by him?

30. Had you lost your purse?

Ans. Had your purse been lost by you?

B. Write the following sentences change the voice :

1. We elected Ramesh captain.

Ans. Ramesh was elected captain by us.

2. Do not insult the weak.

Ans. Let the weak not be insulted.

3. My watch was lost.

Ans. Someone has lost my watch.

4. I saw him opening the box.

Ans. He was seen opening the box by me.

5. We must listen to his words.

Ans. His words must be listened to by us.

14

The Adverb

Underline adverbs in the following sentences and write their kinds in the space provided :

1. She was sitting close to the old man.

Adverb of Place

- | | |
|---|------------------------------------|
| 2. <u>Possibly</u> it is as you say. | Adverb of Assertion |
| 3. I have read this <u>before</u> . | Adverb of Time |
| 4. I hurt my knee <u>yesterday</u> . | Adverb of Time |
| 5. He <u>seldom</u> comes here. | Adverb of Frequency |
| 6. Is the teacher <u>in</u> the class? | Adverb of Place |
| 7. Walk <u>backward</u> . | Adverb of Manner |
| 8. This story is <u>well</u> written. | Adverb of Manner |
| 9. The sailors faced the storm <u>bravely</u> . | Adverb of Manner |
| 10. He is <u>very</u> careless. | Adverb of Degree |
| 11. You are <u>quite</u> mistaken. | Adverb of Degree |
| 12. Try <u>again</u> . | Adverb of Time |
| 13. He is <u>too</u> shy. | Adverb of Degree |
| 14. Do not walk <u>so</u> fast. | Adverb of Degree |
| 15. That is <u>well</u> said. | Adverb of Manner |
| 16. We rose <u>very early</u> . | very (Degree), early (Time) |
| 17. The secret is <u>out</u> . | Adverb of Place |
| 18. Cut it <u>length wise</u> . | Adverb of Manner |
| 19. Are you <u>quite</u> sure ? | Adverb of Degree |
| 20. I am <u>so</u> glad to hear it. | Adverb of Degree |

15

Direct and Indirect Narration

Exercise

A. Write the subject, verb, and object of the Reporting Verb and the Reported Speech separately in the following table:

1. Sonali says to Ritika, "I write a letter."

Ans. Reporting Verb: Subject: Sonali | Verb: says to | Object: Ritika
Reported Speech: Subject: I | Verb: write | Object: a letter

2. Rachna says to Alka. "I sang a song."

Ans. Reporting Verb: Subject: Rachna | Verb: says to | Object: Alka
Reported Speech: Subject: I | Verb: sang | Object: a song

3. Veena says to Jagdish, "I shall cook for you."

Ans. Reporting Verb: Subject: Veena | Verb: says to | Object: Jagdish
Reported Speech: Subject: I | Verb: shall cook | Object: for you

4. The teacher says to the student, "The tiger leapt upon a lamb."

Ans. Reporting Verb: Subject: The teacher | Verb: says to | Object: the student
Reported Speech: Subject: The tiger | Verb: leapt | Object: upon a lamb

5. Ashok says to Sachin, "You hit the ball hard."

Ans. Reporting Verb: Subject: Ashok | Verb: says to | Object: Sachin
Reported Speech: Subject: You | Verb: hit | Object: the ball

Exercise

A. Change the following direct narration into indirect narration:

1. She says to me, "I know you well."

Ans. She says to me that she knows me well.

2. They say, "We are working for our country."

Ans. They say that they are working for their country.

3. My brother says, "Burglars broke into my house last night."

Ans. My brother says that burglars broke into his house last night.

4. She says to me, "I was waiting for your sister."

Ans. She says to me that she was waiting for my sister.

5. She says, "I worked in the office for many years."

Ans. She says that she worked in the office for many years.

6. Karim says, "My friend stayed for two weeks with me."

Ans. Karim says that his friend stayed for two weeks with him.

7. Ghalib says, "I have never met such people before."

Ans. Ghalib says that he has never met such people before.

8. John will say, "Deepak has sung a song for me."

Ans. John will say that Deepak has sung a song for him.

9. Sulochana says, "I shall work hard for success."

Ans. Sulochana says that she will work hard for success.

10. Daler will say, "They will be arriving by the next train."

Ans. Daler will say that they will be arriving by the next train.

11. He says, "I am unwell."

Ans. He says that he is unwell.

12. You say, "My sister is writing letters."

Ans. You say that your sister is writing letters.

13. Gopi says, "I know her address."

Ans. Gopi says that he knows her address.

14. They say, "Chinese is a difficult language."

Ans. They say that Chinese is a difficult language.

15. She says to you, "I don't believe you."

Ans. She tells you that she doesn't believe you

B. Change the following in Direct Narration :

1. He asked Rama to go with him.

Ans. He said to Rama, "Go with me."

2. I told him that I had not seen him for months.

Ans. I said to him, "I have not seen you for months."

3. I told them to be quiet.

Ans. I said to them, "Be quiet."

4. He asked me what I wanted.

Ans. He said to me, "What do you want?"

5. John said that he wanted to be a soldier.

Ans. John said, "I want to be a soldier."

6. He told us that he had waited for an hour.

Ans. He said to us, "I have waited for an hour."

7. An old mouse asked who would bell the cat.

Ans. An old mouse said, "Who will bell the cat?"

16

The Preposition

A. Fill in the blanks with suitable prepositions:

1. Tom sat in the middle.

2. Walking she went into the cup board.

3. I tried to solace him in his grief.

4. The girl sat beside an old woman.

5. The shoes stand under the cot.

6. The friends laughed among themselves.

7. He swore by the name of God.

8. He fall down with his arms on his chest.

9. The lion ran **after** the goat.
10. I don't believe **in** listening to cock and bull stories.
11. She sang **from** morning **till** evening.
12. She poured water **into** a jug.
13. The teacher beat him **with** a stick.
14. I wrote a letter **in** running hand.
15. A naughty monkey sat **on** a tree.

B. Fill in the blanks choosing suitable preposition from the bracket:

1. We penetrated deep **into** the forest.
2. There is peril **to** life in doing this.
3. I differ from you **on** this matter.
4. Is coal tar-derived **from** coal?
5. Rohan is averse **to** hard work.
6. The patient was afflicted **with** epilepsy.
7. That is contrary **to** hard facts of life.
8. The house is infested **with** rats.
9. Sweet music is beneficial **to** mental health.
10. He is given **to** boasting.
11. Dilbar is blind **of** on eye.

17

The Conjunction

A. Using suitable conjunctions, complete the following sentences:

1. Although he is kind **he is strict** .
2. Come in **or go out**.
3. Walk carefully **or you will fall**.
4. Two **and** four .
5. He worked hard **but he failed**.
6. I believe him **because he is honest**.
7. Catch me **if you can**.
8. It is raining outside **so stay inside**.
9. He fled **because he was afraid**.
10. I am sure **that he will come**.

11. Wait **till I return**.
12. I shall do it **when you ask me**.
13. Live **and let live**.
14. Either Geeta **Sita will come**.
15. It is long time **since we met**.

B. Give the following sentences using appropriate conjunctions:

1. She is going to Chennai. Her brother is going to Kolkata.

Ans. She is going to Chennai and her brother is going to Kolkata.

2. The beggar walked towards the dog. The dog did not see him.

Ans. The beggar walked towards the dog but the dog did not see him.

3. She sing sweetly. She sings loudly.

Ans. She sings sweetly and she sings loudly.

4. Tom is running. Christy is skipping.

Ans. Tom is running and Christy is skipping.

5. She must work hard. She will fail.

Ans. She must work hard or she will fail.

6. He failed in the test. He did not work hard.

Ans. He failed in the test because he did not work hard.

7. We could not watch television. The lights went out.

Ans. We could not watch television because the lights went out.

8. My brother is well. My sister is ill.

Ans. My brother is well but my sister is ill.

9. He was poor. He was a hunter.

Ans. He was poor but he was a hunter.

10. You may go. I will stay.

Ans. You may go but I will stay.

11. I know. He does not think so.

Ans. I know but he does not think so.

12. I will come. I am not ill.

Ans. I will come if I am not ill.

13. Sita goes to school. Radha goes to school.

Ans. Sita goes to school and Radha goes to school.

14. He ran to the station. He missed the train.

Ans. He ran to the station but he missed the train.

15. Karim works hard. Abdul works harder.

Ans. Karim works hard but Abdul works harder.

16. Hari does not write fast. He writes very well.

Ans. Hari does not write fast but he writes very well.

17. You must be quiet. You must leave the room.

Ans. You must be quiet or you must leave the room.

18. The sheep are grazing. The oxen are grazing.

Ans. The sheep are grazing and the oxen are grazing.

18 Interjection

A. Fill in the blanks using appropriate interjections:

1. Hurray ! We have won the match !
2. Well done ! You did your best.
3. Oops ! The custard fell on my dress.
4. Wow ! This movie is amazing.
5. Ouch ! It's hurting !
6. Hello ! My name is sam.
7. Alas ! He lost everything in the fire!
8. Bravo ! What a great job!

B. Use exclamation marks in appropriate places and rewrite :

1. Hush don't make a noise.

Ans. Hush! Don't make a noise.

2. Well done I am proud of you.

Ans. Well done! I am proud of you.

3. Bravo you ran well.

Ans. Bravo! You ran well.

4. Thank the lord he has given us everything.

Ans. Thank the Lord! He has given us everything.

C. Match the interjections with the appropriate statements:

Interjections

Statements

1. Hello!
2. Hey!

- How are you?**
- Look at the joker.**

3. Alas!
4. Hurray!
5. Bravo!
6. Oh!
7. Wow!
8. Ouch!

I missed by one mark.
I got a promotion.
Very well tried.
You have come so early.
The embroidery is so nice.
My finger is hurting.

D. Underline the interjections in the following sentences and put them into sentences of your own:

1. Yum! You are the best cook dad!

Ans. Yum! The cake tastes delicious.

2. Oh, I haven't seen my best friend since we left college!

Ans. Oh! I forgot my homework at home.

3. Oops! I dropped the bowl of porridge.

Ans. Oops! I spilled the water.

4. No! Don't play with that!

Ans. No! I don't want to go there.

19

Bio-Sketch Writing

A. Write a brief (100 words) biographical sketch of the famous sitarist, Pandit Ravi Shanker. Take help from the given clues :

Pandit Ravi Shankar was a famous Indian sitarist and one of the greatest musicians of India. He was born on 7 April 1920 in Varanasi. He learned sitar under the guidance of the great musician Allauddin Khan. He worked as the music director of All India Radio, New Delhi from 1949 to 1956. His performances in Europe and America made Indian classical music popular worldwide. He performed with famous artists like Yehudi Menuhin and George Harrison. He was nominated to the Rajya Sabha from 1986 to 1992. He received the Bharat Ratna in 1999 and three Grammy Awards. He died on 11 December 2012.



B. Write a brief (100 words) biographical sketch of the famous boxer, Muhammad Ali. Take help from the given clues :

Muhammad Ali, originally named Cassius Marcellus Clay, was a world-famous boxer known as "The Greatest." He was born on January 17, 1942. He followed an unorthodox boxing style and relied on his speed and skills. He won the World Heavyweight Championship in 1964 and regained it in 1974. In 1978, he became the first boxer to win the title three times. He



was declared the sportsman of the century in 1999. After retirement, he supported education and promoted adoption. Muhammad Ali passed away on June 3, 2016, leaving behind a great legacy.

20 Message Writing

Note: This chapter is only for reading and practice.

21 Notice Writing

Write notices based on the following situations:

1. **You are the Principal of APJ International School, New Delhi. Write a notice announcing that the school will remain closed on a particular day to celebrate India's victory in the World Cup cricket tournament.**

APJ INTERNATIONAL SCHOOL, NEW DELHI

NOTICE

Date: 20 November 2025

SCHOOL HOLIDAY

This is to inform all students that the school will remain closed on 21 November 20XX to celebrate India's victory in the World Cup cricket tournament.

All students will resume classes as usual the next day.

(Principal)

APJ International School

2. **You are the Activity Secretary of Holy Ganga School, New Delhi. Your school is Organising an Inter - House Quiz Competition for classes VI, VII and VIII. Draft a notice mentioning the date and venue of the competition. You may also mention that interested students should submit their names to their respective House Captains by a particular date.**

HOLY GANGA SCHOOL, NEW DELHI

NOTICE

Date: 10 August 2025

INTER-HOUSE QUIZ COMPETITION

The school is organising an Inter-House Quiz Competition for classes VI, VII and VIII on 25 August 20XX in the school auditorium.

Interested students must submit their names to their respective House Captains by 18 August 20XX.

(Activity Secretary)

3. **Imagine that you are the Cultural Secretary of your school. Draft a notice to inform children about an Inter-Class Folk Dance competition which will be organised in school and give the required details. You may request the class monitors to give the list of participants by a particular date.**

DPS SCHOOL, NEW DELHI

NOTICE

Date: 5 September 2025

INTER-CLASS FOLK DANCE COMPETITION

An Inter-Class Folk Dance Competition will be held on 20 September 20XX in the school auditorium.

All class monitors are requested to submit the list of participants by 15 September 2025.

(Cultural Secretary)

4. **You are Kanak Tiwari of Class VIA, Roll No 8. Mamta Modern School, Delhi. You have lost your tiffin box probably in the school canteen. Write a notice to be put up on the school notice board.**

MAMTA MODERN SCHOOL, DELHI

NOTICE

Date: 12 July 20XX

LOST! LOST! LOST!

I have lost my tiffin box in the school canteen. It is of steel and has a blue lid.

Anyone who finds it is requested to return it to the undersigned.

Kanak Tiwari

Class VI A (Roll No. 8)

5. **You are Amrita Gupta of Class VI A. You have found a geometry box in the school library. Write a notice mentioning where, when and from whom the box can be collected.**

ABC SCHOOL, DELHI

NOTICE

Date: 18 July 2025

FOUND! FOUND! FOUND!

A geometry box has been found in the school library on 17 July 20XX.

The owner can collect it from the undersigned during school hours after identifying it.

Amrita Gupta

Class VI A

22 Paragraph Writing

2. Write notices based on the following situations:

1. An unforgettable day of my life

One of the most unforgettable days of my life was when I won my first school competition. I had worked hard for weeks, practicing every day after school. When my name was announced as the winner, I felt a mix of surprise and happiness. My teachers congratulated me, and my parents were proud of my achievement. That day taught me that hard work and determination always pay off. I still remember the applause and the joy I felt. It remains a special memory that motivates me whenever I feel discouraged.

2. A Birthday Party

Last year, I attended a wonderful birthday party of my close friend. The house was beautifully decorated with balloons and lights. There were games, music, and delicious food. We laughed, danced, and took many pictures together. The highlight was the cake-cutting ceremony, where everyone sang loudly and cheered. I gave my friend a gift, and he was very happy. The party created many joyful memories, and I enjoyed every moment of it. It was truly a fun and lively celebration.

3. A Memorable Bus Ride

One of my most memorable bus rides was during a school trip. The journey was full of excitement as we sang songs, shared snacks, and laughed together. The scenery outside the window was beautiful, with green fields and hills passing by. At one point, the bus stopped near a small village, giving us a chance to stretch and explore. The ride brought us closer as friends and made the trip even more enjoyable. It was not just a journey but an experience I will always cherish.

4. If I Could Be Invisible for a Day!

If I could be invisible for a day, I would use the opportunity to observe the world in a unique way. I would visit places where I normally cannot go and learn how people behave when they think no one is watching. I might help others secretly, like solving small problems without expecting recognition. However, I would be careful not to misuse this power. Being invisible would teach me responsibility and the importance of honesty. It would be an exciting yet thoughtful experience.

5. Early Life of Isaac Newton

Isaac Newton was born in 1643 in England. His early life was not easy, as his father died before he was born. Newton was a quiet and curious child who showed great interest in learning. He attended school in Grantham and later studied at Trinity College, Cambridge. During his youth, he developed a strong passion for science and mathematics. His early experiences and dedication laid the foundation for his future discoveries, making him one of the greatest scientists in history.

6. How I Picture Myself Four Years from Now

Four years from now, I see myself as a confident and successful individual. I hope to complete my education with good results and gain valuable skills. I imagine myself working towards my career goals with dedication and discipline. I also want to be more independent and responsible. Along with professional growth, I aim to maintain good relationships with family and friends. I believe that with hard work and determination, I can achieve my dreams and build a bright future for myself.

23 Dairy Writing

1. **In a class test you scored less than some of your friends. You have not told your parent about your marks. Write a diary entry mentioning what you thought and how you plant face your parents.**

Date: 12 July 2025

Day: Monday

Place: Home

Dear Diary,

Today was not a good day for me. We got our class test results and I scored less marks than many of my friends. I feel very upset and disappointed. I had studied, but maybe not enough.

I have not told my parents yet because I am afraid they will be angry. But I know hiding the truth is not right. I am thinking to tell them honestly tomorrow.

From now on, I will work harder and prepare better for my exams. I don't want to feel like this again.

2. **Some situations are given below. Write diary entries based on them.**

(i) How did you spend your weekend? Write a few lines.

Date: 10 July 2025

Day: Sunday

Place: Home

Dear Diary,

This weekend was really enjoyable. I spent time with my family. On Saturday, I watched a movie and played games with my friends.

On Sunday, we went to the park and had a picnic. The weather was pleasant and I felt very happy.

I wish every weekend could be like this!

(ii) You are a girl. There was a quarrel between you and your younger brother. Your grandmother intervened in the matter but favoured your brother though he was wrong. Write about how did you feel?

Date: 8 July 2025

Day: Thursday

Place: Home

Dear Diary,

Today I had a quarrel with my younger brother. He took my things without asking and we started fighting.

Grandmother came and tried to solve the matter, but she supported my brother even though he was wrong. This made me feel very sad and hurt.

I feel that no one understood my side. But now I think fighting is not the solution. I will try to stay calm next time.

(iii) It is a day before your examination. You have studied hard, but you are tense and worried. Write a diary entry about your feelings and anxiety and how prayer help you to calm down.

Date: 14 July 2025

Day: Wednesday

Place: Home

Dear Diary,

My exams are starting tomorrow. I have studied a lot, but still I feel nervous and worried. I keep thinking about the questions and whether I will do well.

In the evening, I prayed to God and it made me feel calm and relaxed. I believe everything will go well.

I will try my best and stay confident.

(iv) Write a diary entry for the day you are learning this lesson.

Date: 15 July 2025

Day: Thursday

Place: School

Dear Diary,

Today we learned about diary writing in class. It was very interesting. I understood how to express personal feelings and thoughts.

The teacher explained that a diary should be honest and personal. I enjoyed writing my own diary entry.

I think writing a diary is a good habit and I will start writing daily.

24 Comprehension

1. Complete the following statements:

(i) The author of the above passage advises the students that ..

Ans. The author advises students that they should think for themselves and not follow others blindly.

(ii) A student should learn thinking for himself because

Ans. A student should learn thinking for himself because it helps him understand things better and form his own opinions.

2. Tick (✓) the correct answer:

(i) If a student does not agree with the teacher in the class, he should

Ans. (a) think upon it himself
(d) disclose the fact to the teacher without hesitation

(ii) When a student says that he does not agree with him, a good teacher feels

Ans. (b) glad

3. Pick out the words from the given passage which mean the following :

(i) only - mere

(ii) learn by heart - **commit to memory**

II. Radio broadcasts started in India in 1927 with two privately owned transmitters at Mumbai and Kolkata. The government of India took them over in 1930 and started operating them under the name of the Indian Broadcasting Service. In 1936, the name of the service was changed to All India Radio. Since 1957, it is known as Akashvani. The AIR's external services broadcasts are meant to project a true and objective image of the country's point of view on matters of national and international importance. Vividh Bharati Service of All India Radio is the largest entertainment network of the nation. Since its launch in 1957, Vividh Bharati has been providing popular and

melodious entertainment to the listeners. With its wide network consisting of 37 Vividh Bharati Centers and some Local Radio Stations, it now reaches more than 97% population of this country. Vividh Bharati Programmes are also very popular in the neighbouring countries.

1. Answer these questions:

(i) When and where were the first radio broadcasting transmitters started?

Ans. In 1927 at Mumbai and Kolkata.

(ii) What action did the Government take?

Ans. The Government took over the transmitters in 1930 and started operating them as the Indian Broadcasting Service.

(iii) What does the AIR's external services broadcast?

Ans. It broadcasts a true and objective image of the country's point of view on national and international matters.

2. Fill in the blanks:

(i) Vividh Bharati Service of All India Radio is the largest entertainment network of the nation.

(ii) In 1936, the name of the service was changed to All India Radio.

(iii) There are 37 Vividh Bharati Centers in the country.

1

Kinds of Sentences

Grammar-7

A. Tick (✓) the correct option :

1. This classroom is green.

Ans. (a) declarative

2. What is the name of your class teacher ?

Ans. (b) interrogative

3. Mrs. Maya is my class teacher.

Ans. (a) declarative

4. My classmates love me very much.

Ans. (a) declarative

5. Wow you did a great job!

Ans. (c) exclamatory

B. Punctuation means putting a full stop, a question mark or a mark of exclamation at the end of a sentence. Add the correct punctuation at the end of the following sentences then write whether the sentence is Declarative, Interrogative, or Exclamatory in the space provided :

- | | | |
|---|---|----------------------|
| 1. I told her to wear a blue shirt | - | Declarative |
| 2. Do you have your homework | - | Interrogative |
| 3. We will have recess at 10:30 today | - | Declarative |
| 4. Yes, that was our teacher | - | Declarative |
| 5. They walked to the mall together | - | Declarative |
| 6. Did you listen to the Prime Minister's message | - | Interrogative |

C. Write the following kinds of sentences on your own :

- | | | |
|------------------|---|----------------------------------|
| 1. Declarative | - | I like reading books. |
| 2. Declarative | - | She plays in the park. |
| 3. Interrogative | - | Where are you going? |
| 4. Interrogative | - | Do you like ice cream? |
| 5. Exclamatory | - | What a beautiful day! |
| 6. Exclamatory | - | Hurray! We won the match! |

D. Rewrite the following sentences so that they are not confusing :

1. Running down the street, I watched my dog.

Ans. I watched my dog running down the street.

2. Our dog has a pink tongue and a long tail who barks a lot.

Ans. Our dog has a pink tongue and a long tail. It barks a lot.

3. Singing in the shower, I heard my dad.

Ans. While I was singing in the shower, I heard my dad.

4. Flying the kite, the trees got in the way.

Ans. While I was flying the kite, the trees got in the way.

5. The stranger arrived, the dog barked.

Ans. When the stranger arrived, the dog barked.

6. The play started, we were not allowed to talk.

Ans. When the play started, we were not allowed to talk.

E. Transform each sentence from one type to the type indicated below. You can add, remove or re-arrange words. Don't forget to pay attention to punctuation. Use the codes given below :

Codes:

D → E = Declarative to Exclamatory I → D = Interrogative to Declarative

I → E = Interrogative to Exclamatory D → IM = Declarative to Imperative

1. Does Dad mind riding on swings ? (I → D)

Ans. Dad minds riding on swings.

2. Before our car starts to travel upward, Mom says, "Hold on." (D → IM)

Ans. Hold on before the car starts to travel upward.

3. I love amusement parks. (D → E)

Ans. How much I love amusement parks!

4. Of all the rides at the amusement park, are roller coasters the best? (I → D)

Ans. Roller coasters are the best rides at the amusement park.

5. It's amazing, we scream. (D → E)

Ans. How amazing it is!

6. Can you think of more fun ? (I → E)

Ans. What more fun there is!

2

Collective Nouns

A. Write suitable collective nouns for the following. Take help from the words given in the box:

1. a **brood** of chickens.

2. a **bundle** of sticks.

3. a **litter** of puppies.
4. a **set** of tools.
5. an **album** of photographs.
6. a **grove** of trees.

B. Match each collective noun with its group :

| Collective Noun | Group or Unit |
|---------------------------|--|
| 1. An agenda | (e) of tests is hard work |
| 2. A gang | (a) of thieves stole the money |
| 3. Litter | (b) of kittens meowed for food |
| 4. The herd | (d) of elephants stomped through the jungle |
| 5. We each picked a bunch | (c) of juicy grapes from the vines |
| 6. The gaggle | (f) of geese flew overhead |

C. Fill in the blanks with correct collective nouns given in the brackets:

1. The **orchestra** played for the enthusiastic **audience** .
2. The **herd** of sheep was saved from a **pack** of wolves.
3. She wore a beautiful dress out of her **collection** of dresses and had a **bunch** of flowers in her hand.
4. We made a **batch** of cookies for our **family**.
5. The **board** of directors was waiting for the order of the **jury** of judges.
6. The **tuft** of grass was so soft that a big **herd** of goats ate it up quickly.

3

Possessive Pronouns

A. Choose the correct possessive pronouns from the given sentences and tick (✓) the correct option :

1. This notebook is his.

Ans. (a) his

2. Priya is well known for her cooking talent.

Ans. (b) her

3. The dictionary has no longer its cover.

Ans. (d) its

4. This pair of shoes is yours.

Ans. (c) yours

5. The dog lost its bone in the boat.

Ans. (a) its

B. Rewrite the following sentences replacing the possessive pronouns correctly :

1. This car is you.

Ans. This car is yours.

2. The bicycle is I.

Ans. The bicycle is mine.

3. The red house is we.

Ans. The red house is ours.

4. The saree is she.

Ans. The saree is hers.

5. We met Versha and Badal yesterday. This photograph is they.

Ans. We met Versha and Badal yesterday. This photograph is theirs.

6. The belt is he.

Ans. The belt is his.

7. This bag is she.

Ans. This bag is hers.

8. In the zoo, there lives a peacock. The nest is it.

Ans. In the zoo, there lives a peacock. The nest is its.

9. The blue car is we.

Ans. The blue car is ours.

10. This was not my fault. It was you.

Ans. This was not my fault. It was yours.

4

Demonstrative Pronouns

A. Use this or these :

1. Is **this** my drink?

2. **These** aren't my teachers.

3. Is **this** an interesting museum.

4. **These** are new shoes.

5. **This** is my puppy.

6. **This** is a laptop.

7. **These** are donkeys.

8. What is **this**?

B. Use that or those :

1. **That** a very tall building.

2. **Those** are her CDs.

3. Are **those** your books.

4. **That** is a big shop.

5. **That** is Nisha's house.

6. **That** is a mountain.

7. **Those** are horses.

8. What are **those**?

C. Use this or these :

1. **This** is my desk.

2. **These** are my pets.

3. **This** is Tamanna's bag.

4. It is raining again. **This is awful** is awful.

5. Hello Kunal, **this** is Bharat.

6. **This** is my friend, Pankhudi.

7. **These** mangoes tastes delicious.

8. I don't like **this** one.

D. Use that or those :

1. Who owns **that** house?

2. Look at **that** man over there.

3. **That** is a computer.

4. **That** woman is an engineer.

5. **That** is my sister.

6. Wasn't **that** a horrible thing to say ?

7. **That** is my cousin, Yashi.

8. Don't take **that** mug.

E. Fill in the blanks with the correct demonstrative pronouns :

1. Look, right here, this is the solution, I want to show you.

2. Look at the animals over there, have you seen **those** before ?

3. This picture was taken in 2024. Do you remember this?

4. Come and look at these.

5. I think I heard something, did you hear that?

6. Hello Hina, this is my friend Disha.

7. That was very far from here.

8. These paintings are more famous than those.

5

Distributive Pronouns

A. Choose the correct distributive pronoun and tick (✓) the correct option :

1. _____ boy was given a prize.

Ans (d) Every

2. _____ team could win a decisive victory.

Ans (a) Either

3. She had a child hanging on to _____ hand.

Ans (b) either

4. _____ road will lead to the airport.

Ans (a) Either

5. _____ of them wanted to visit her in the hospital.

Ans (d) Neither

6. I don't hate _____.

Ans (c) either

7. Were _____ students present in your class ?

Ans (a) all

8. _____ book was of any use to him.

Ans (c) Neither

B. Fill in the blanks with distributive pronouns :

1. **Each** of the girls was late.

2. **Each** of the boys is healthy.

3. **Each** of you can finish the project.

4. **Each** of these kids were laughing.

5. **Every** boy was allowed to play outside.

6. **All** of them went on the trip.

7. There are many tourists coming here every day. **Each** has a camera.

8. I will have one **each** to go.

9. **None** of these answers is correct.

10. I like **either** of the two jeans.

11. You may bring **any** of your friends.

12. **Many** of our students failed last year.

13. You may answer **either** of these (two) questions first.

14. **Each** of the desks needs to be cleaned.

15. **One** of these boys must have taken my hanky.

6

Demonstrative Adjectives

A. Tick (✓) the correct demonstrative adjectives :

1. Please pass me ___ cards.

Ans. (c) these

2. I have to take ___ DVDs back to the store.

Ans. (c) those

3. Can you move ___ books into the other room?

Ans. (c) those

4. ___ is my favourite type of ice-cream.

Ans. (b) This

5. Which of the following contains a demonstrative adjective ?

Ans. (d) those socks

6. Which of the following contains a demonstrative adjective used correctly?

Ans. (b) this car

7. Choose the correct sentence :

Ans. (c) Divya loves these peanuts.

8. Which sentence is incorrect ?

Ans. (b) Rohan owns these motorcycle.

B. Fill in the blanks with correct distributive adjectives given in the brackets :

1. **This** cooker is very hot.

2. Can you see **that** bird ?

3. **These** flowers smell nice.

4. **This** phone has user-friendly interface.

5. Do you remember about the book **that** we saw in the book fair ?

6. There are ten students in the classroom. Two of **those** students are boys.

7. **those** shops were closed 5 years ago.

8. Look at **that** bicycle, it is such a dirty one.

C. Fill in the blanks with correct distributive adjectives :

1. Please bring back **those** books before night.

2. I have a mechanical toy **that** looks like a robot.
3. Whose books are **these** ?
4. I wonder who painted **that** portrait we saw it last night
5. **Those** people over there come from Pakistan.
6. Some of **these** lessons are really helpful to us.
7. **That** car is expensive, isn't it.
8. **These** exercises are useful for you !

7

Forming Comparative and Superlative Adjectives

A. Fill in the blanks with the comparative form of the adjectives given in brackets :

1. My house is **smaller** than yours.
2. Learning Chinese is **more difficult** than learning French.
3. The Pacific Ocean is **deeper** than the Arctic Ocean.
4. A lotus is **more beautiful** than a rose.
5. My brother is **taller** than me, but he is younger, too.
6. The Earth is **larger** in diameter than the moon.
7. It is **farther** from New Delhi to Dehrrun than it is from New York to Gurgaon.
8. You are **more polite** than my friend.

B. Fill in the blanks with the superlative form of the adjectives given in brackets :

1. Deep is the **least** worried about the game.
2. That was the **best** movie ever.
3. Jupiter is the **biggest** planet in our Solar System.
4. She is the **slimmest** girl in our class.
5. This is the **most interesting** book I have ever read.
6. I can't find my **most comfortable** shirt.
7. Mount Everest is the **highest** mountain in the world.
8. My brother is the **smartest** person in my family.

C. Complete the comparative and the superlative forms of the following adjectives :

| Adjectives | Comparative | Superlative |
|------------|--------------|--------------|
| 1. little | less | least |
| 2. much | more | most |
| 3. some | more | most |
| 4. nervous | more nervous | most nervous |

| | | | |
|-----|---------|--------------|--------------|
| 5. | many | more | most |
| 6. | new | newer | newest |
| 7. | old | older | oldest |
| 8. | perfect | more perfect | most perfect |
| 9. | quick | quicker | quickest |
| 10. | rich | richer | richest |
| 11. | sad | sadder | saddest |
| 12. | simple | simpler | simplest |
| 13. | small | smaller | smallest |
| 14. | smart | smarter | smartest |
| 15. | soft | softer | softest |

8

Uses of Adjectives

A. Tick (✓) the correct adjectives :

1. There were _____ people present at the meeting.

Ans. (c) many

2. Taxes have to be paid by _____ citizen.

Ans. (d) every

3. They have finished _____ of the rice.

Ans. (b) most

4. New Delhi is _____ city than Ghaziabad.

Ans. (a) larger

5. The police officer is _____ than the thief.

Ans. (b) younger

6. Chintan is the _____ of all the students.

Ans. (d) tallest

7. Adding _____ sugar will make the coffee tastier.

Ans. (a) some

8. I am the _____ student in the class.

Ans. (d) smallest

B. Find appropriate forms of adjectives indicating number, quantity, age, time and position :

1. Few patients look well.

Ans. Number

2. There are twenty-five students in my class.

Ans. Number

3. I ate some cake.

Ans. Quantity

4. Dad will go for a walk later.

Ans. Time

5. Between the two heroines, the latter is more beautiful.

Ans. Position

6. Simmi is the eldest child of her parents.

Ans. Age

C. Fill in the blanks with appropriate forms of adjectives indicating number, quantity, age, time and position :

1. What is the **latest** news of your city ?

2. Students, get ready for the **next** chapter.

3. They all will join you **later**.

4. I need **some** help from your part.

5. Bhawna is **younger** than Shakshi.

6. Between the principal and the teacher, I think the **latter** is more proficient in work.

7. Neha is the **tallest** of all the students.

8. Adding **some** sugar will make the coffee tastier.

9. **Few** patients look well.

9

Transitive and Intransitive Verbs

A. Five of these sentences include transitive verbs, and five include intransitive verbs. Write T for transitive or I for intransitive in the space provided :

- | | |
|--|---|
| 1. These plants need more sunshine during the next few weeks. | T |
| 2. The rain came suddenly. | I |
| 3. Drivers noticed the many potholes on the roads last spring. | T |
| 4. Mrs. Sharma helped Mrs. Verma find her son, Bharat. | T |
| 5. Lakshmi danced gracefully at the party. | I |
| 6. Harsh rested often during the challenging climb. | I |
| 7. A police officer examined the suspected people. | T |
| 8. You do not need to help yet. | T |
| 9. My dog ran away last night. | I |
| 10. We witnessed the beautiful sunrise. | T |

B. Underline the verbs and state whether they are transitive or intransitive. Circle the direct objects. One has been done for you :

- | | |
|---|---------------------|
| 1. The customers <u>formed</u> long <u>queue</u> outside the shop. | <u>Transitive</u> |
| 2. Do you <u>play</u> <u>tennis</u> every day? | <u>Transitive</u> |
| 3. Have you ever <u>explored</u> <u>the internet</u> ? | <u>Transitive</u> |
| 4. I must <u>buy</u> new <u>shirts and shoes</u> this year. | <u>Transitive</u> |
| 5. My plans for the new house <u>were</u> incomplete. | <u>Intransitive</u> |
| 6. Diane <u>tripped</u> on the top step and <u>fell</u> downstairs. | <u>Intransitive</u> |

C. Make sentences using the following transitive verbs :

- | | |
|----------|--------------------------------------|
| 1. write | She wrote a letter. |
| 2. play | He plays cricket. |
| 3. fell | She fell the tree. |
| 4. stop | The police stopped the car. |
| 5. kill | The hunter killed a deer. |
| 6. eat | I eat an apple daily. |
| 7. sing | She sings songs. |
| 8. dance | She danced a classical dance. |

D. Make sentences using the following intransitive verbs :

- | | |
|-------------|-------------------------------|
| 1. cry | The baby cried loudly. |
| 2. sleep | He slept peacefully. |
| 3. go | They went home. |
| 4. come | She came early. |
| 5. fall | The leaves fell down. |
| 6. do drink | He drinks regularly. |
| 7. weep | She wept bitterly. |
| 8. laugh | They laughed loudly. |

10

Non-finite Verbs

A. Identify non-finite verbs in the following sentences and write if they are gerund, infinitive or participle :

1. Having lost all of my money, I went home.

Ans. **Having lost** – Participle

2. Everyone wanted to go.

Ans. **to go** – Infinitive

3. Travelling might satisfy your desire for new experiences.

Ans. Travelling – Gerund

4. We must study to learn.

Ans. to learn – Infinitive

5. Having finished her work, she went home.

Ans. Having finished – Participle

6. They do not appreciate my singing.

Ans. singing – Gerund

B. Join the following sentences using participles or infinitives :

1. The tea is too hot. I cannot drink it.

Ans. The tea is too hot to drink.

2. She ran out of the room. She was screaming.

Ans. She ran out of the room screaming.

3. I didn't know what to do. I called the police.

Ans. Not knowing what to do, I called the police.

4. Every man should do his duty. Our country expects this.

Ans. Every man should do his duty to meet what our country expects.

5. I received no reply. I sent another letter.

Ans. Having received no reply, I sent another letter.

6. The proposal is quite unreasonable. It cannot be accepted.

Ans. The proposal is too unreasonable to be accepted.

C. Circle the gerunds and underline the present participles in the following sentences :

1. Reading helps you learn perfectly.

Ans. Reading – Gerund

2. When you moan, you're much more convincing.

Ans. (No gerund/participle)

3. The children come running.

Ans. running – Present participle

4. He enjoys working.

Ans. working – Gerund

5. I prefer eating rice.

Ans. eating – Gerund

6. Her favourite hobby is reading.

Ans. reading – Gerund

D. Fill in the blanks with the -ing form of the verbs given in the box :

1. **Making** fun of others is a bad habit.
2. **Listening** to music relaxes our mind.
3. **Putting** excessive burden on head is harmful.
4. **Running** in the morning is not good for health.
5. **Sleeping** away from problems is not a solution.
6. **Walking** is a good exercise.

11

Phrasal Verbs

A. Tick (✓) the correct option :

1. Every morning I (stop sleeping) _____ when I hear the alarm clock.

Ans. (b) wake up

2. On Sundays I can (leave bed) _____ later.

Ans. (c) get up

3. We must (be quick) _____ or we'll be late for school!

Ans. (c) hurry up

4. Om helped the old lady to (board) _____ the bus.

Ans. (b) get on

5. Sonam went to the library to (try to find) _____ a book.

Ans. (c) look for

B. Fill in the blanks with correct phrasal verbs given in the box

1. You must **give back** the book that I lend you.
2. Uncle Tarun promises he will **give up** smoking soon.
3. They **carry on** talking when the teacher arrives.
4. The firefighters came and **put out** the fire.
5. I will call the salesman to **find out** the price.
6. You never forget the place where you **grow up**.
7. If your car **breaks down**, you should call a garage.
8. It is difficult for an aeroplane to **take off** when there is heavy fog.

12

Determiners

A. In each of the following sentences, indicate whether the coloured word is a numeral or a determiner :

1. Five twos are ten.
2. Seven is my lucky number.

Numeral

Numeral

- | | |
|---|-------------------|
| 3. Dev was the last to arrive, as usual. | Determiner |
| 4. Each cricket team consists of eleven players. | Numeral |
| 5. They gave me a second chance. | Determiner |

B. In each of the following sentences, indicate whether the coloured word is a determiner or a pronoun :

- | | |
|--|-------------------|
| 1. These questions are easy. | Determiner |
| 2. This play of yours - what's it about ? | Determiner |
| 3. Is this yours ? | Pronoun |
| 4. These are really tasty. | Pronoun |
| 5. Can I borrow some sugar? | Determiner |

C. Fill in the blanks with correct determiners :

- Dad saw **a** gentleman lying on the road.
- You can directly look at the moon, but you can't look directly at **the** sun.
- Is there any pistachio left in **the** jar ?
- I need to pack **an** orange for my lunch.
- The boys were **each** given a test paper.
- The police officer spoke separately to **each** suspect.
- She was wearing a bracelet on **her** wrist.
- I got my lost wallet without **any** problem.
- I don't think **anyone** is coming to the party, except Judy and Stan.
- I always keep **some** books on my study table.

13 Articles

A. Fill in the blanks with a or an :

- Simran is **an** honest girl.
- He wrote **a** letter to his mother.
- Someone who reads books finds **a** lot of peace of mind.
- My mother is **a** M.A.
- An** apple a day keeps a doctor away.
- A** goat bleats.
- An** ass is a beast of burden.
- She had **a** rimmed hat.

B. Fill in the blanks with a, an and the, and put a cross (X) if none of them is necessary :

1. ~~X~~ Ganga is a holy river.
2. **The** Rajya Rani Express is the fastest ~~X~~ train on this route.
3. ~~X~~ Indians worship their gods and goddesses.
4. He is the most intelligent boy of our ~~X~~ class.
5. My friend bought a bike.
6. His father is an MBBS. He lives in a big city.
7. **The** Business Standard is a newspaper which is popular in Delhi besides in a few other cities.
8. **A** king lived in a big ~~X~~ palace.

14

Omission of Articles

A. Tick (✓) the box if the sentence is right. Otherwise, cross (X) the box and rewrite the correct sentences in the space provided. One has been done for you :

- | | |
|---|-------------------------------------|
| 1. The children learn easily what they see. | <input type="checkbox"/> |
| <u>Children learn easily what they see.</u> | |
| 2. Sugar has lots of calories. | <input checked="" type="checkbox"/> |
| 3. Where is the sugar I bought? | <input checked="" type="checkbox"/> |
| 4. Life is difficult in this area because there isn't enough water. | <input checked="" type="checkbox"/> |
| 5. Music makes me happy. | <input checked="" type="checkbox"/> |
| 6. The book we were reading is not costly but it is very interesting. | <input checked="" type="checkbox"/> |
| 7. Friends should help you when you need it. | <input checked="" type="checkbox"/> |
| 8. The friends I was waiting for arrived this morning. | <input checked="" type="checkbox"/> |
| 9. Indian people are really hard-working. | <input checked="" type="checkbox"/> |
| 10. I can't play the piano. | <input checked="" type="checkbox"/> |

B. Rewrite the following sentences correctly :

- | | |
|--------------------------------------|------------------------------------|
| 1. They went there by a sea. | They went there by sea. |
| 2. She worked hard all the day. | She worked hard all day. |
| 3. The football is the popular game. | Football is a popular game. |
| 4. He doesn't like the apples. | He doesn't like apples. |

5. An iron is very hard.
6. Honesty is my motto.
7. She went to the school every day.
8. Grandma goes to the temple in the morning.

Iron is very hard.
Honesty is my motto.
She goes to school every day.
Grandma goes to the temple in the morning.

15 Kinds of Adverbs

A. Underline the adverbs in the following sentences and state their kinds. You must also mention the question these adverbs answer. One is done for you :

1. Uncle Joe often goes out for shopping.

Ans. Often – Adverb of Frequency

Question: When does Uncle Joe go out for shopping?

2. Peter ran quickly to catch the ball.

Ans. Quickly – Adverb of Manner

Question: How did Peter run?

3. Chintoo went out.

Ans. Out – Adverb of Place

Question: Where did Chintoo go?

4. Tarak went to the circus yesterday.

Ans. Yesterday – Adverb of Time

Question: When did Tarak go to the circus?

5. Mrs. Sharma rang the bell twice.

Ans. Twice – Adverb of Frequency

Question: How many times did Mrs. Sharma ring the bell?

6. The king will buy some horses tomorrow.

Ans. Tomorrow – Adverb of Time

Question: When will the king buy horses?

7. Pooja rarely makes mistakes.

Ans. Rarely – Adverb of Frequency

Question: How often does Pooja make mistakes?

8. The child slept soundly.

Ans. Soundly – Adverb of Manner

Question: How did the child sleep?

B. Fill in the blanks with the right kind of adverb according to the hint given. The same adverb can be used more than once :

1. My uncle live in Chennai. I visit them **often**.
2. My friends are **only** South Indians.
3. I have **never** been to the USA.
4. I have been to Shimla just **once**.
5. I was **very** impressed with her performance.
6. I **often** go for a walk in the park.
7. I watch English films **sometimes**.

16

Position of Adverbs

A. Tick (✓) the correct option :

1. We are _____ ready.

Ans. (b) almost

2. They may _____ have used this method.

Ans. (c) already

3. I have _____ said that.

Ans. (b) just

4. She has been attending the English class _____.

Ans. (b) regularly

5. This can _____ be true.

Ans. (a) certainly

6. The experiment has _____ been done like this.

Ans. (c) never

7. I _____ understand what you mean.

Ans. (a) quite

8. He is _____ back.

Ans. (d) already

B. Tick (✓) the correct positions where the adverbs given in the brackets most likely to be used :

1. We have **already** made some radical changes.
2. The discussion **usually** takes one hour.
3. He **sometimes** helps us with the experiments.
4. The world is **constantly** changing.

5. They **finally** agreed on the higher education reform.
6. They discussed the issue **thoroughly**.
7. The problem will **hopefully** be solved by tomorrow.
8. They discussed the differences between the calculated and measured values **thoroughly**.

C. Rewrite the following sentences using the adverbs given in brackets in their correct positions :

1. Did you enjoy the flight ? (both)

Ans. Did you both enjoy the flight?

2. Manya watches TV. (hardly) (ever)

Ans. Manya hardly ever watches TV.

3. He drives his car. (Carefully)

Ans. He drives his car carefully.

4. The children play football. (in the garden)

Ans. The children play football in the garden.

5. We went to the mall. (yesterday)

Ans. We went to the mall yesterday.

6. Daksh fell off the bike. (almost)

Ans. Daksh almost fell off the bike.

7. My parents will buy a new house. (probably)

Ans. My parents will probably buy a new house.

8. The teacher is going to school soon. (definitely)

Ans. The teacher is definitely going to school soon.

17

Formation of Adverbs

A. Form adverbs to the following :

- | | | | |
|----------------|----------------------|--------------|----------------------|
| 1. cheap | cheaply | 2. loud | loudly |
| 3. full | fully | 4. fantastic | fantastically |
| 5. correct | correctly | 6. careful | carefully |
| 7. happy | happily | 8. true | truly |
| 9. intelligent | intelligently | 10. good | well |
| 11. silly | sillily | 12. probable | probably |
| 13. fair | fairly | 14. busy | busily |
| 15. far | far | 16. powerful | powerfully |
| 17. direct | directly | 18. hopeful | hopefully |
| 19. wise | wisely | 20. extreme | extremely |

B. Find the adjective in the first sentence and fill the blanks with the adverb. First one has been done for you :

1. Jatin is happy. He smiles **happily**.
2. The painter is awful. He paints **awfully**.
3. Dhruv is a wonderful piano player. He plays the piano **wonderfully**.
4. Mahima is very quiet. She often sneaks out of the house **quietly**.
5. Yash is loud. He shouts **loudly**.
6. Her English is fluent. She speaks English **fluently**.
7. My grandma was angry. She spoke to us **angrily**.
8. Raja is a careless driver. He drives **carelessly**.
9. She is a good dancer. She dances really **well**.
10. This exercise is simple. You **simply** have to put one word in each space.

18

Active and Passive Voice

A. Tick (✓) the correct passive voice sentence :

1. Who ate the last biscuit ?

Ans. (a) The last biscuit was eaten by whom ?

2. He painted the entire house.

Ans. (b) The entire house was painted by him.

3. Mom read the novel in one day.

Ans. (b) The novel was read by Mom in one day.

4. The science class viewed the comet.

Ans. (a) The comet was viewed by the science class.

B. Fill in the blanks with one of the verbs given in the box. Use the correct form of verbs :

1. The room **was cleaned** by me yesterday.
2. The window **was closed** by the servant.
3. Letters **were written** by my friend.
4. The thief **was** finally **arrested** by the police.
5. His birthday **was celebrated** by the party.
6. The scientists **are testing** the new drug for cancer.

C. Change the following sentences from active voice to passive voice :

1. Someone stole my books.

Ans. My books were stolen by someone.

2. Who is repairing your cellphone ?

Ans. By whom is your cellphone being repaired?

3. Plantation workers raise coffee.

Ans. Coffee is raised by plantation workers.

4. Hundreds of tourists visit this museum every year.

Ans. This museum is visited by hundreds of tourists every year.

5. Some children were visiting the Red Fort while I was there.

Ans. The Red Fort was being visited by some children while I was there.

6. Children cannot open these bottles easily.

Ans. These bottles cannot be opened easily by children.

19

Direct and Indirect Speech

A. Tick (✓) the correct option :

1. Simran asked her sister _____ she always got up early.

Ans. (c) if

2. The policeman asked me _____ I was in such a hurry to cross the road.

Ans. (c) whether

3. You asked me _____ I was wasting my time.

Ans. (b) why

4. Jyotsna asked the servant _____ he had found the key anywhere.

Ans. (c) whether

5. Mother told me that she _____ waiting for me for a long time.

Ans. (d) had been

6. He also told her that she _____ not get a pet dog.

Ans. (d) should

7. The dentist _____ him to brush his teeth twice a day.

Ans. (a) advised

8. The teacher asked Kim _____ she had been waiting for.

Ans. (c) for whom

B. Rewrite the following sentences in indirect speech. You may use the clues given in the brackets. One has been done for you :

1. How stupid my servant is! (woman)

Ans. The woman exclaimed that her servant was very stupid.

2. Won't you help me to carry this box? (friend)

Ans. The friend requested me to help him carry that box.

3. You must not scream loudly. (doctor, caution, patient)

Ans. The doctor cautioned the patient not to scream loudly.

4. Please forgive me this time. (policeman, thief, plead)

Ans. The thief pleaded with the policeman to forgive him that time.

5. Get ready to attack the enemy. (chief, black commando, order)

Ans. The chief ordered the black commandos to get ready to attack the enemy.

6. I bought this gold ring for my mother. (son, his)

Ans. The son said that he had bought that gold ring for his mother.

7. Please say nothing about this. (he, her)

Ans. He requested her to say nothing about that.

8. Ice floats on water. (science teacher, class)

Ans. The science teacher told the class that ice floats on water.

C. Change the following from indirect to direct speech :

1. I say that I want to sleep.

Ans. I say, "I want to sleep."

2. You said that they were waiting for the bus.

Ans. You said, "They were waiting for the bus."

3. She told me that she was not going to see me.

Ans. She said to me, "I am not going to see you."

4. Komal asked her uncle if he could take her to the mall at once.

Ans. Komal said to her uncle, "Can you take me to the mall at once?"

5. They said that they liked these books.

Ans. They said, "We like these books."

6. She asked you when you would start from London.

Ans. She said to you, "When will you start from London?"

7. Lord Rama said that a fine lesson would be taught to the wicked Ravana.

Ans. Lord Rama said, "A fine lesson will be taught to the wicked Ravana."

20

The Simple Tense

A. Put the verbs in the correct tense :

1. They **were discussing** the matter with me while I **was working** on the computer.

2. He **was sitting** in the sun when he **remembered** something.

3. While the beggar **was running** across the road, a truck **ran** over him.

4. He **died** while he **trying** to save his friend.

5. When the phone **rang**, I **was having** a bath.

B. Complete the following in the simple past tense :

1. The cows **grazed** in the meadow.

2. She **did not read** the newspaper.
3. Why they **did they shout** at you ?
4. It **got** darker each minute.
5. A man **tried** to cross the road at that moment.
6. How they **did they prepare** for the show ?

C. Fill in the blanks using the simple past and the past perfect tense of the verbs given in the brackets :

1. Chetna **was** very happy that day, she **won** the dance competition.
2. I **was** very tired yesterday, I **had worked** hard all day.
3. When I **reached** the airport, the flight **had left** already.
4. The rat **had escaped** before the cat **arrived**.
5. grandma **went** to bed after she **had said** her prayers.

D. Complete the following using the simple past and the past perfect continuous appropriately :

1. At last, I (find) my lost pen. I (look) for it from many days.

Ans. At last, I found my lost pen. I had been looking for it for many days.

2. He (have) a large amount of money in the bank. He (save) all his earnings.3

Ans. He had a large amount of money in the bank. He had been saving all his earnings.

3. When I (get) home last night everyone (sleep).

Ans. When I got home last night, everyone had been sleeping.

4. He (write) all day, but he (not finish) the report.

Ans. He had been writing all day, but he did not finish the report.

5. At last, the sun (come) out. It (rain) non-stop for a week.

Ans. At last, the sun came out. It had been raining non-stop for a week.

21

The Continuous Tense

A. Fill in the blanks with verb in the present continuous tense :

1. Who is **telling** you to learn well ?
2. I am **attending** dance class now-a-days.
3. All the guests are **gossiping** in the party hall.
4. Is it regularly **happening** in your class ?
5. Ekta **is going** to school by her car.

B. Fill in the blanks with the verb in the past continuous tense :

1. Pinki and Karan **were playing** in the park.
2. Varun and Vani **were** not **reading** newspaper.

3. Harnam **was dancing** to the tunes on the floor.
4. We **were listening** to pop music in the room.
5. Ranvir **was writing** a poem in his diary.

C. Rewrite the following sentences changing the tense of the verb according to the instructions in the brackets. You can make necessary changes :

1. Dad left for Paris. He attended a seminar. (future continuous)

Ans. Dad will be leaving for Paris and will be attending a seminar.

2. The woman on the back seat complained. (past continuous)

Ans. The woman on the back seat was complaining.

3. We had not received any information from her. (present continuous)

Ans. We are not receiving any information from her.

4. Our servant walked so fast that he became breathless. (past continuous)

Ans. Our servant was walking so fast that he became breathless.

5. The dog happily chases its own tail for hours. (present continuous)

Ans. The dog is happily chasing its own tail for hours.

6. The security guard whistled at night. (future continuous)

Ans. The security guard will be whistling at night.

22 The Perfect Tense

A. Fill in the blanks with verb in the present perfect tense :

1. The children **have drawn** beautiful pictures.
2. The servant **has managed** the things very carefully.
3. Mom **has** already **ironed** my shirt.
4. He **has deposited** the money in the bank.
5. She **has borrowed** many books from the library.
6. The advocate **has given** advice to the client.

B. Fill in the blanks with verb in the past perfect tense :

1. **Had** you **told** the truth to the principal before he left for the meeting ?
2. Disha and Dhruv **had** not **finished** their meal when we arrived.
3. Who **had bought** the ticket before you reached there ?
4. People **had** not **understood** the reality before the detective made revelation.
5. Shubham **had left** the bag before I reached home.
6. Roma **had sung** a sweet song before the principal stood up.

C. Rewrite the following sentences changing the tense of the verb according to the instructions in the brackets. You can make necessary changes :

1. I was watching Discovery Channel. (past perfect)
I had watched Discovery Channel.
2. She had finished her homework by noon. (present perfect)
She has finished her homework by noon.
3. The show will begin when you reach the auditorium. (present perfect)
The show has begun when you reach the auditorium.
5. The clinic had been closed when the patient reached. (past perfect)
The clinic had been closed when the patient reached.
6. We shall be reaching the station around then. (future perfect)
We shall have reached the station around then.

23 The Perfect Continuous Tense

A. Fill in the blanks with the verb in the present perfect continuous tense :

1. She **has been going** to the cinema every weekend for years.
2. Bruno, my lovely dog **has been hiding** under the sofa for over an hour now.
3. Mohit **has been sneezing** since he got here.
4. Samad **has been working** as an artist since he graduated.
5. What **have** you **been doing** since mom left ?
6. They **have been working** day and night on this road, so now it's time to relax and have some fun.
7. She **has been studying** in this school since July.

B. Fill in the blanks with the verb in the past perfect continuous tense :

1. He wasn't hungry because **he had been eating** all day long.
2. Bhumi gained weight because she **had been eating** pizza three times a day.
3. He **had been partying** all night, so he fell asleep in class.
4. Dad **had been flying** for three hours before they finally reached Singapore.
5. You **had been sitting** there for more than an hour before he arrived.
6. We were thirsty because we **had been playing** out outside in the heat.
7. She **had been struggling** for several years before she died.

C. Fill in the blanks with the verb in the future perfect continuous tense :

1. Aryan will be tired when he gets here because he **will have been exercising** for one hour.
2. The chauffeur **will have been driving** for an hour by the time he gets home.

3. In November, we **will have been living** in Spain for eleven years.
4. Even though she **will have been dancing** the whole night, Munmun will still look very fresh.
5. How long **will** you **have been studying** when you get your degree?
6. In December, I **will have been working** here for two years.
7. By the end of the day, he **will have been carrying** ninety bags of wheat on his back.

24

Linking Words or Conjunctions

A. Tick (✓) the sentences which contain correct conjunctions to combine each pair of sentences :

1. The sun came out. The day was still cold.

Ans. (a) The sun came out, but the day was still cold.

2. The bear came closer. We began to feel threatened.

Ans. (c) We began to feel threatened when the bear came closer.

3. Animals all need water. They may die without it.

Ans. (c) Animals all need water, but they may die without it.

4. I wanted to go to the party. I got sick.

Ans. (c) I wanted to go to the party, but I got sick.

5. Dolphins live underwater. Sharks live underwater.

Ans. (b) Dolphins and Sharks live underwater.

6. Winning was a challenge. Our team could do it.

Ans. (c) Winning was a challenge, but our team could do it.

7. My brother wants to win the trophy. I want to win the trophy.

Ans. (b) My brother and I want to win the trophy.

8. The sun came out. The ice began to melt.

Ans. (a) The sun came out and the ice began to melt.

B. Combine the pairs of sentences using the conjunction given in the brackets :

1. I was ill **even though** I had to work.

2. We phone you, **but** you never receive it.

3. You can go **when** you finish the work.

4. They came to the party **despite** not being invited.

5. She studied hard **so that** she didn't fail the exam.

6. He doesn't stay here **since** he left last Wednesday.

7. Mom has taken leave for a week **because of** her brother's marriage.

8. The house caught fire **so** he didn't put out the candle.

9. You'll get an accident **unless** you are careful.

10. We enjoyed the holiday **in spite of** the rain every day.

C. Circle the correct linking word to complete the conversation :

Sandy : Have you got any plans after / since you finish college ?

Mandy : Tony and I are planning to go to France if / unless we can afford it.

We have saved some money so / so that we can go to our favourite place.
In case / unless we go to France, we'll visit Paris first.

Sandy : That sounds great. How are you travelling there ?

Mandy : By air. Our thoughts aren't here since / until we made this plan. It will be expensive but / despite it'll be interesting.

D. Fill in the blanks with the appropriate word from those given in the box :

1. She took some extra books so that he could read them during the journey.
2. He was dishonest, but he was elected the president.
3. She changed her occupation in order to earn more money.
4. Take an umbrella when you go out in case it rains.
5. It was important, so I phoned you, but you weren't available.

25 Idioms

A. Underline the idioms used in the following sentences :

1. Rajat is a chicken.
2. Vidya visits her uncle off and on.
3. The rains threw the city life out of gear.
4. They went to the party with bells on.
5. She told a white lie about her failure.
6. Jatin is a quick study.
7. He has his hands full today.
8. My cousin hasn't dropped me a line this week.
9. She cannot help me, as she is broke.
10. That sum is a piece of cake for my sister.
11. Divya, don't be a couch potato.
12. Why are you jumping all over me ?

B. Write sentences of your own using the given idiom. Meanings of idioms and examples have also been given :

1. have one's hands full (be extremely busy)

Ans. have one's hands full: I cannot go out today because I have my hands full with homework.

2. hit the books (study)

Ans. hit the books: I need to hit the books as my exams are near.

3. be all ears (be eager to hear what someone has to say) Tell me what do you want to say. I'm all ears !

Ans. be all ears: Tell me your problem, I am all ears.

4. be broke (be without money) He is unable to lend you any money. He is completely broke.

Ans. be broke: I cannot buy this game because I am broke.

5. jump to conclusions (decide something too quickly and without considering all facts) I think Manisha doesn't like me. She avoids talking to me. You're jumping to conclusions. Actually, she's shy.

Ans. jump to conclusions: Don't jump to conclusions without knowing the truth.

6. keep one's chin up (remain confident in a difficult situation; not to worry too much) I know it's a difficult task, but you will succeed if you keep your chin up.

Ans. keep one's chin up: Even in tough times, you should keep your chin up.

7. keep/stay in touch (to remain in contact by writing, calling, sending e-mail, etc) We haven't seen our teacher for some days, but we keep (stay) in touch by e-mail.

Ans. keep/stay in touch: We stay in touch through phone calls.

8. live from hand to mouth (live with great difficulty especially because you have little money) His family has been living from hand to mouth since he lost his job.

Ans. live from hand to mouth: Many poor families live from hand to mouth.

26 Notice Writing

Write notices on the following topics :

1. St. Joseph Public School,
Gwalior

Date: 10 July, 2025

Notice

This is to inform all students that our school is hosting an Inter-School Basketball Tournament. Students are invited to attend and cheer for the participants.

Date: 20 July, 20XX

Time: 9:00 a.m.

Venue: School Playground

For more details, contact the undersigned.

Isha Parikh

(Sports Secretary)

2. Mother Teresa Sr. Secondary School,
Ranikhet

Date: 5 August, 2025

Notice

This is to inform all students that a Russian Ballet Troupe will perform on the occasion of our school's Golden Jubilee celebrations.

Date: 15 August, 2025

Time: 11:00 a.m.

Venue: School Auditorium

All students are requested to attend.

Bulbul

(President, Students' Union)

3. Human Value Public School,
Navi Mumbai

Date: 12 September, 2025

Notice

Our school is organizing a Cultural Fiesta to raise funds for the War Widows' Welfare Fund. Students are invited to participate and contribute generously.

Various programmes and stalls will be organised.

Date: 25 September, 2025

Time: 11:00 a.m.

Gunjan Bhatnagar

(Cultural Secretary)

4. J.B Public School,
Noida

Date: 3 April, 2025

Notice

Students interested in joining the school cricket team are requested to submit their names for selection.

Trials Date: 10 April, 20XX

Time: 8:00 a.m.

Venue: School Ground

Contact the undersigned for details.

Sports Secretary

4. Modern Public School,
Jaipur

Date: 18 November, 2025

Notice

The Science Forum is organizing a lecture by an eminent scientist. All students are invited to attend and gain knowledge.

Trials Date: 25 November, 2025

Time: 12:00 noon

Venue: School Hall

Attendance is compulsory.

Payal

(Secretary, Science Forum)

27 Message Writing

Read the following conversation between Raja and Prince, and then write the message for Bhuvan :

Raja : Hello! Is that Bhuvan?

Prince : I am sorry, he is not at home. I'm his elder brother. May I know who is calling ?

Raja : I am Raja Rajput.

Prince : Do you have a message?

Raja : Yes, I am coming to Dehradun by Shatabdi Express. Ask him to pick me up from the station at 11:30 p.m. My Coach / Seat No. is D-2/45.

Prince : I'll pass on your message.

Raja : Thanks.

Prince : You are welcome.

MESSAGE

10 December, 20XX

11:30 p.m.

Dear Bhuvan,

There was a telephone call for you from your friend Raja Rajput. He said that he is coming to Dehradun by Shatabdi Express. Please go to the station to pick him up at 11:30 p.m. His coach and seat number are D-2/45.

Prince

28 Articles Writing

A. Read the following articles and think of an appropriate title for each one :

TITLE : **Leprosy – A Growing Disease**

- (1) The oldest known disease to human kind, and the first to be identified, is on the increase. It is now prevalent in twenty-four countries, and doctors are still unsure or what causes leprosy. There is a general consensus that it could be contracted through the respiratory system, but as of yet, there is no solid evidence. On the other hand, it could be spread by touch. Leprosy is curable if detected in the early stages, but what are the symptoms?

TITLE : **Difficulties in Learning a New Language**

- (2) Learning another language is not an easy process due to-different word order, irregular verbs, tricky prepositions, difficult-to-pronounce, strange-looking vocabulary. There are also many methods on offer to accomplish this feat-so many in fact, that it can become confusing and hard to decide which is the best method for you. Courses on cassette, evening classes, private lessons, a language school, move to the country where the target language is spoken(an extreme method, perhaps), a correspondence course, or having a pen friend-the list is endless and it feels like a jungle when trying to decide what to try.

29 Essay Writing

A. Write an essay on Saina Nehwal :

Saina Nehwal is a legendary figure in Indian sports who brought badminton into the national limelight. As a former World No. 1, she broke numerous barriers and proved that Indian athletes could dominate on the global stage. Her journey is a source of immense inspiration for aspiring sportspersons across the country.

Born in 1990 in Haryana, Saina inherited her passion for sports from her parents, both of whom were former state-level badminton players. After moving to Hyderabad, her father encouraged her to take up the sport professionally. Her family made significant sacrifices, including long commutes and financial investments, to ensure she received the best coaching and equipment.

Her career is decorated with historic achievements and prestigious awards. She became the first Indian badminton player to win an Olympic medal by securing a bronze at the 2012 London Games. Additionally, she has won over 24 international titles, including the Commonwealth Games gold and several Super Series titles, making her one of the most successful athletes in India.

Saina has made India proud by instilling a sense of confidence in the youth. By consistently defeating top-seeded international players, she ended the global monopoly of other nations in badminton. Her legacy lives on as she continues to be a role model for discipline and excellence, putting India firmly on the world badminton map.

B. Use this graphic organiser to write your essay :



30 Reading Comprehension

Exercise

A. From your reading of the passage, complete the following statements :

1. The country close to the Philippine Islands is **China**.
2. Manila is in the **Philippine Islands**.
3. Many **languages** are spoken in the Philippine Islands.
4. The weather of the islands is **very warm**.
5. The houses of the Moro are built of **bamboo**.

B. Describe the houses on the Philippine Islands.

Ans. The houses in the Philippine Islands are not very high but are beautiful. Some have strange windows made of oyster shells instead of glass. These shells are thin and allow light to pass through. Some houses also have sliding walls to let cool air enter the rooms.

C. How are the houses of the Moro tribe different from the houses of the other Philippines?

Ans. The houses of the Moro tribe are different because they are built in water near the shore on long poles. They are raised high above the water and people use ladders to reach them. Other houses are built on land and have shell windows.

D. Write the comparative and superlative forms of these adjectives from the passage :

| Adjective | Comparative | Superlative |
|------------|-------------|-------------|
| 1. Small | Smaller | Smallest |
| 2. Strange | Stranger | Strangest |

- | | | |
|--------------|----------------|----------------|
| 3. Thin | Thinner | Thinnest |
| 4. Beautiful | More beautiful | Most beautiful |

Exercise

Answer these questions :

1. How does the author describe rain?

Ans. The author describes rain as wet, white, and like a puddle and a leak in the sky. It makes us happy, helps things grow, and can be gentle or wild.

2. What all can rain do?

Ans. Rain can make things grow, create rainbows, make the earth smell good, flood the land, and even make houses and people swim.

3. What do children feel like doing when it rains?

Ans. Children feel like playing in the rain, blowing soap bubbles, and sailing paper boats in puddles.

4. Why do mothers scream and shout when it rains? What are some of the things they say?

Ans. Mothers scream and shout because children get wet and make things dirty.

They say things like:

“Come inside, at once.”

“Don’t wet the carpet.”

“Don’t bring your muddy shoes into the house.”

5. What poetic conclusion does the author make about rain at the end?

Ans. The author concludes that rain makes us poetic, hungry, and wise, and calls it summer’s very special prize.

A. Read the following sentences and write their types :

- | | |
|--|---|
| 1. We should hate the crime, and not the criminal. | Assertive Sentence |
| 2. Can I tell this to your mother? | Interrogative Sentence |
| 3. Why has she not come on time? | Interrogative Sentence (Wh-type) |
| 4. Always help the needy. | Imperative Sentence |
| 5. Prerna goes to school in the morning. | Assertive Sentence |
| 6. Kartik does not do his work honestly. | Assertive Sentence (Negative) |
| 7. There are seventeen boys and ten girls in my class. | Assertive Sentence |
| 8. Which computer did he buy yesterday? | Interrogative Sentence (Wh-type) |

B. Write twelve sentences of your own: three assertive, three interrogative, three imperative, and three exclamatory sentences:

| | |
|---|---|
| <p>Assertive Sentences</p> <ol style="list-style-type: none"> I like reading books. She is my best friend. The sun rises in the east. | <p>Interrogative Sentences</p> <ol style="list-style-type: none"> Where do you live? Are you ready? Why are you late? |
| <p>Imperative Sentences</p> <ol style="list-style-type: none"> Close the door. Please help me. Do your homework. | <p>Exclamatory Sentences</p> <ol style="list-style-type: none"> What a beautiful day! Wow! That is amazing! How fast he runs! |

C. Rewrite the following sentences by replacing the full forms with correct contractions :

- | | |
|-------------------------------------|--|
| 1. Let us revise the lesson. | Let's revise the lesson. |
| 2. Who are you looking for ? | Who're you looking for? |
| 3. If you are confident, go ahead. | If you're confident, go ahead. |
| 4. Nobody knows what is the matter. | Nobody knows what's the matter. |
| 5. They are not wasting their time. | They aren't wasting their time. |
| 6. I will be waiting for you. | I'll be waiting for you. |

D. Complete the following sentences with tag questions :

- He is an honest man, **isn't he?**
- She is not a dancer, **is she?**
- My father is a famous doctor, **isn't he?**

4. Can't you help me, **can you**?
5. The weather isn't pleasant, **is it**?
6. Let's have a glass of milk, **shall we**?

2

Nouns

A. Pick out the nouns in the following sentences and state their kinds :

1. The Ganga is a sacred river.

Ans. **Ganga** – Proper noun **river** – Common noun

2. Gold is the precious metal.

Ans. **Gold** – Material noun **metal** – Common noun

3. Boys and girls, men and women, children and grown-ups, all went to the zoo.

Ans. **Boys, girls, men, women, children, grown-ups** – Common nouns **zoo** – Common noun

4. Slavery is a curse for mankind.

Ans. **Slavery** – Abstract noun **mankind** – Collective noun

5. Eleven players make a cricket team.

Ans. **players** – Common noun **team** – Collective noun

6. Childhood is free from all worries.

Ans. **Childhood** – Abstract noun **worries** – Abstract noun

7. The crowd gathered to see the Prime Minister.

Ans. **crowd** – Collective noun **Prime Minister** – Proper noun

8. Firoz Khan is a great actor.

Ans. **Firoz Khan** – Proper noun **actor** – Common noun

9. She was reciting a poem.

Ans. **actor** – Common noun

10. He left for England.

Ans. **England** – Proper noun

B. Form abstract nouns from the following adjectives :

- | | | | |
|-----------|-----------------|----------|------------------|
| 1. wise | wisdom | 2. good | goodness |
| 3. vacant | goodness | 4. sweet | sweetness |
| 5. human | humanity | 6. free | freedom |
| 7. proud | pride | 8. brave | bravery |
| 9. novel | novelty | 10. poor | poverty |

C. Write whether the coloured noun are countable or uncountable :

- | | |
|--|-------------|
| 1. How many politicians does it take to pass a simple law? | Countable |
| 2. The children fell asleep quickly after a busy day of fun. | Countable |
| 3. Be careful! The water is deep. | Uncountable |
| 4. The parade included tanks and military jeeps. | Countable |
| 5. My son can play several different musical instruments. | Countable |
| 6. I was feeling so stressed that I ate an entire box of biscuits. | Countable |
| 7. Most children like milk, but Yash hates it. | Uncountable |
| 8. Most pottery is made of clay. | Uncountable |
| 9. We like the large bottles of cold drinks. | Countable |
| 10. This baker uses real butter in the cakes she bakes. | Uncountable |

3

Agreement of Verb with the subject

A. Complete the following sentences using suitable verbs :

1. The life span of mosquitoes is very short.
2. You and he are doing the work.
3. The General as well as his staff is there.
4. Plucking flowers is forbidden.
5. Neither Vani nor Pran is present in the school.
6. We are not going to the park today.
7. The sun is shining brightly.
8. The people are to the mall.
9. Do our soldiers fight bravely ?
10. A man is selling beautiful dresses.

B. In pairs, discuss what is wrong with each of following sentences :

1. The Rhymes are in the pre-primary syllabus.

Ans. The rhymes are in the pre-primary syllabus.

2. The news are too good to be true.

Ans. The news is too good to be true.

3. Bread and milk are my dog's only food.

Ans. Bread and milk is my dog's only food.

4. Each of his brother are good.

Ans. Each of his brothers is good.

5. One of my friends play chess perfectly well.

Ans. One of my friends plays chess perfectly well.

C. Tick (✓) the correct verb given in the brackets :

1. The family dog (**is**, are) named Clifford.
2. Clifford (**is**, are) a huge golden retriever.
3. The silly dog (love, **loves**) to chase the water from the sprinkler.
4. As the sprinkler (sling, **slings**) the water, Clifford (snap, **snaps**) at it.
5. The neighbours (**laugh**, laughs) at him.
6. He also (chase, **chases**) butterflies in the yard.
7. I am not sure what he (think, **thinks**) they are.
8. I don't think he (**has**, have) ever caught one.
9. I wonder what the butterflies (**think**, thinks) about our goofy dog.
10. Although he likes to chase butterflies, he never (chase, **chases**) rabbits.

D. Underline the verb in each sentence. If the subject and verb do not agree, Encircle it and write the correct verb form in the space provided. If it is correct, then write 'CORRECT' in the space provided :

1. The cutest little bird (have) built a nest in our apple tree. **has**
2. She (work) all day on her nest. **works**
3. She has even lined it with grass to make it soft. **Correct**
4. I hope she (are) going to lay eggs in it very soon. **is**
5. I (thinks) baby birds are so cute! **think**
6. They sound so sweet when they chirp for their mother. **Correct**
7. My family (enjoy) watching the mother bird while she teaches them how to fly. **enjoys**
8. When they (is) trying to learn to fly, I wonder if they are scared. **are**
9. We (is) going to watch for the baby birds to hatch this year. **are**
10. They will be safe because the mother bird (are) building a good nest. **is**

4

Modals

A. Tick (✓) the correct option :

1. _____ I have more cheese on my sandwich?

Ans. (b) could

2. You _____ eat more vegetables.

Ans. (a) should

3. I _____ like to buy the same television for my house.

Ans. (c) would

4. _____ I have a cup of coffee please?

Ans. (c) may

5. You _____ smoke near children.

Ans. (c) shouldn't

6. The passengers _____ wear their seatbelts at all times.

Ans. (b) must

7. We _____ go to the concert if the rain stops. We don't know for sure.

Ans. (b) might

8. I _____ ice skate very well.

Ans. (a) can

9. The boys _____ wake up earlier than 7:30 am. They have class at 8:00 am.

Ans. (d) have to

10. The rock band _____ play very well last year. Now they are much better.

Ans. (b) couldn't

B. Use modals to frame questions from the given statements :

1. Asking for the phone number.

Ans. Could you tell me your phone number, please?

2. You want the TV to be switched off.

Ans. Could you switch off the TV, please?

3. You want a glass of water.

Ans. May I have a glass of water, please?

4. Asking the name of a stranger.

Ans. Could you tell me your name, please?

5. Seeking permission to take someone's pen.

Ans. May I use your pen, please?

5

Adjectives

A. Put appropriate Comparative or Superlative Degrees to each of the following :

1. Sachin Tendulkar is the **best** batsman in the world.
2. Honour is **dearer** to him than life.
3. The Eiffel Tower is **taller** than Qutab Minar.
4. Vani is the **most intelligent** girl in the class.
5. Mumbai is the **biggest** city in India.
6. Param is **taller** than Daksh.
7. This is the **better** of two books .
8. This is the **best** she can do.
9. Yesterday was the **hottest** day of the month.
10. Ankush has got the **highest** marks in the class.

B. Point out the Adjectives and name the Degree of Comparison of each .

1. The poor man had seen the happiest days.

Ans. **happiest** → Superlative Degree

2. Dev is the idlest boy in the class.

Ans. **idlest** → Superlative Degree

3. He thinks he is stronger than his brother.

Ans. **stronger** → Comparative Degree

4. My dad is elder than my uncle.

Ans. **elder** → Comparative Degree

5. Laughter is the best medicine.

Ans. **best** → Superlative Degree

6. He has many good friends.

Ans. **many, good** → Positive Degree

7. Krish is an intelligent boy.

Ans. **intelligent** → Positive Degree

8. Name the best city in the world.

Ans. **best** → Superlative Degree

9. Rohan is the best boy in the class.

Ans. **best** → Superlative Degree

6

Articles

A. Fill in the blanks with A or AN :

1. **A** bed
2. **A** chair
3. **An** egg
4. **A** fish
5. **An** answer
6. **A** song
7. **A** vacation
8. **An** investigation
9. **computers**
10. **An** old letter
11. **A** very sad story
12. **A** web site
13. **An** Internet conference
14. **An** extremely large dog
15. **A** light meal
16. **A** fantastic answer
17. **An** unusually small head
18. **A** funny joke
19. **An** expensive purse
20. **hard lessons**

B. Fill in the blanks with A, AN or THE :

1. My mother is **a** doctor and my father is **an** author.
2. Chintan recommended **a** good dentist, but **the** dentist doesn't have any openings for two months.
3. Mt. Hood is **a** volcano in Oregon. It's **a** very beautiful mountain.
4. Darpan recommended **a** book to Lakshya. He didn't like **the** book at all.
5. Do you have **a** vacuum cleaner? I dropped **a** piece of cake, and I need to clean it up.
6. Honey, where's **the** vacuum cleaner? I can't find it. It was in **the** closet, but now it's not there.
7. Do you have **a** dictionary? I don't have one, and I need to look up **a** word.
8. Do you have **a** passport? You need **a** passport to travel outside of country.
9. There's **a** big bear in **the** backyard. I think **the** bear is looking for something to eat.
10. Do you have **a** computer? I have **a** laptop and **an** iPad.

7

Pronouns

A. Tick (✓) the correct option :

1. Pronouns take the place of

Ans. a. a noun

2. What do pronouns help us add to our speech and writing?

Ans. b. variety

3. What sort of pronouns are the words 'he', 'me' and 'you'?

Ans. c. personal

4. Which personal pronoun is almost always used for a thing?

Ans. b. it

B. Underline pronouns in the following sentences and write their types :

1. This is her pen.

Possessive pronoun

2. Neither of her brothers is handsome.

Indefinite pronoun

3. A few are so lucky.

Indefinite pronoun

4. He is an engineer.

Personal pronoun

5. These are their shirts.

Demonstrative pronoun

C. Fill in the suitable pronouns :

1. Whose is this bike? Is it really **yours**?

2. Is he **your** teacher?

3. Hey Ron! This is not **your** car. **It** is red.

4. Lisa broke **her** left leg.

5. **My** friend lives in a big house, but **mine** is much bigger.

D. Rewrite the following sentences changing the plural pronouns :

1. You can depend on my doing my best.

Ans. You can depend on our doing our best.

2. He has presented me a beautiful watch.

Ans. They have presented us a beautiful watch.

3. She must do her duty.

Ans. They must do their duty.

4. He has no house of his own.

Ans. They have no house of their own.

5. He will support his friends.

Ans. They will support their friends.

E. Join the following sentences using the relative pronouns :

1. The man is honest. The man is trusted.

Ans. The man who is honest is trusted.

2. Here is the purse. You lost it yesterday.

Ans. Here is the purse which you lost yesterday.

3. We saw a boy. He was eating food.

Ans. We saw a boy who was eating food.

4. I hate those people. They are cruel.

Ans. I hate those people who are cruel.

5. He is a rogue. No one trusts him.

Ans. He is a rogue whom no one trusts.

6. This is the road. The road leads to the station.

Ans. This is the road which leads to the station.

8

Preposition and Prepositional Phrases

A. Underline each preposition or compound preposition :

1. Vani is shy so she hides behind the TV.
2. "You are in the class," said the teacher.
3. It will run below the board planks.
4. I am with him at the bay.
5. He will travel beyond all understanding.
6. I got all of the things on the list except the worms.
7. He ran between the buildings.
8. He jumped off the cliff.
9. He rode the cow towards the moons.
10. The candy is inside the store around the corner.

B. Use the following in sentences of your own :

1. Astonished of → **I was astonished at his performance.**
2. Avail of → **You should avail of this opportunity.**
3. Afraid of → **She is afraid of dogs.**
4. Addicted to → **He is addicted to video games.**
5. Accused of → **He was accused of stealing money.**
6. Act upon → **Please act upon my advice.**
7. Bent on → **She is bent on becoming a doctor.**
8. Blind to → **He is blind to his mistakes.**
9. Fond of → **I am fond of music.**
10. Knock at → **Someone is knocking at the door.**

C. Rewrite the following sentences correctly :

1. He fell in the well.

Ans. He fell into the well.

2. I am tired with your work.

Ans. I am tired of your work.

3. Gagan was very kind on me.

Ans. Gagan was very kind to me.

4. Daksh will pass in the examination.

Ans. Daksh will pass the examination.

5. I received your letter at this address.

Ans. I received your letter at this address.

6. Your son is not afraid from you.

Ans. Your son is not afraid of you.

7. We entered into the mall.

Ans. We entered the mall.

8. Students will inform to the Principal.

Ans. Students will inform the Principal.



Active and Passive Voice

A. Change the following sentences into the active voice :

1. The building was damaged by the storm.

Ans. The storm damaged the building.

2. Can it be repaired?

Ans. Can someone repair it?

3. The child was attended to by the doctor.

Ans. The doctor attended the child.

4. Sanskrit is taught by us by Mrs. Mamta.

Ans. Mrs. Mamta teaches us Sanskrit.

5. By whom has this crime been committed ?

Ans. Who has committed this crime?

6. Is a noise being made by the children?

Are the children making a noise?

7. We are delighted by the quality of your work.

Ans. The quality of your work delights us.

8. The entire building was struck by fire.

Ans. Fire struck the entire building.

9. Have your orders been carried out by them?

Ans. Have they carried out your orders?

10. The narrative was eagerly listened to by the director.

Ans. The director eagerly listened to the narrative.

B. Rewrite the following sentences in the passive voice :

1. Rachna will give you some advice.

Ans. You will be given some advice by Rachna.

2. I sent him an e-mail.

Ans. He was sent an e-mail by me.

3. The old woman showed us the way.

Ans. We were shown the way by the old woman.

4. Our neighbour gave me a lift.

Ans. I was given a lift by our neighbour.

5. We have asked him a favour.

Ans. He has been asked a favour by us.

6. She told me a lie.

Ans. I was told a lie by her.

7. They have written her a letter.

Ans. A letter has been written to her by them.

8. Darpan will make you a cup of tea.

Ans. You will be made a cup of tea by Darpan.

9. The waiter has not brought us the coffee.

Ans. We have not been brought the coffee by the waiter.

10. They did not offer her a seat.

Ans. She was not offered a seat by them.

C. Change the following sentences into passive voice ;

1. Open the door.

Ans. Let the door be opened.

2. Do your work.

Ans. Let your work be done.

3. Please sit down.

Ans. You are requested to sit down.

4. Catch the ball.

Ans. Let the ball be caught.

5. Please come in.

Ans. You are requested to come in.

6. Silence please!

Ans. Silence is requested

7. Please have dinner with us.

Ans. You are requested to have dinner with us.

8. Please stand up.

Ans. You are requested to stand up.

9. Help the poor.

Ans. Let the poor be helped.

10. Bring me a glass of water.

Ans. Let me be given a glass of water.

D. Go to the vegetable market and see what is happening there. Then, using the past continuous passive of the verbs write ten sentences here :

Do it yourself.

10

Direct and Indirect Speech

A. Change the following into indirect speech :

1. He said to me, "He is a fool."

Ans. He told me that he was a fool.

2. Our science teacher said, "Light travels in a straight line."

Ans. Our science teacher said that light travels in a straight line.

3. Badal said to the girl, "I know you and your brother well."

Ans. Badal said to the girl that he knew her and her brother well.

4. The teacher said to his disciple, "God rules and governs all things."

Ans. The teacher said to his disciple that God rules and governs all things.

5. The woman says, "I shall kill the cockroach."

Ans. The woman said that she would kill the cockroach.

6. I said, "I am doing my homework."

Ans. I said that I was doing my homework.

7. Mrs. Kaur says, "ten and ten make twenty."

Ans. Mrs. Kaur said that ten and ten make twenty.

8. The father said to his son, "I refuse to take you there."

Ans. The father told his son that he refused to take him there.

9. You said to me, "I have written a book."

Ans. You told me that you had written a book.

10. He says, "I need money."

Ans. He said that he needed money.

B. Change the following into indirect speech :

1. The thief said to the judge, "Please pardon me this time. I shall not steal again."

Ans. The thief requested the judge to pardon him that time and said that he would not steal again.

2. "Stop writing," said the superintendent to the candidates, "Deliver the answer books to the supervisors on duty."

Ans. The superintendent ordered the candidates to stop writing and to deliver the answer books to the supervisors on duty.

3. The beggar said, "Kindly give me some clothes."

Ans. The beggar requested to be given some clothes.

4. The poor man said, "Please allow me to work."

Ans. The poor man requested to be allowed to work.

5. He said to the king, "Kindly allow me to meet my children before I die."

Ans. He requested the king to allow him to meet his children before he died.

6. The doctor said to the child, "Take more of milk. Do not eat sugar candies."

Ans. The doctor advised the child to take more milk and not to eat sugar candies.

7. The accused said to the judge, "Sir, forgive me for my sins."

Ans. The accused begged the judge to forgive him for his sins.

8. She said to his friend, "Don't buy this shirt."

Ans. She advised her friend not to buy that shirt.

9. She said to his friend, "Please pardon me for having disturbed you at this late hour."

Ans. She requested her friend to pardon her for having disturbed him at that late hour.

C. Change the following into indirect speech :

1. He said, "How terrible the night is!"

Ans. He exclaimed that the night was very terrible.

2. They said, "What costly jeans these are!"

Ans. They exclaimed that those jeans were very costly.

3. The old man said, "Alas! I cannot see his face again."

Ans. The old man exclaimed with sorrow that he could not see his face again.

4. He said, "Alas! I am undone."

Ans. He exclaimed with sorrow that he was undone.

5. She said, "Bravo! You have played well."

Ans. She exclaimed with joy that I had played well.

6. "Bravo! A great victory!" they cried.

Ans. They exclaimed with joy that it was a great victory.

7. I said, "How stupid I have been!"

Ans. I exclaimed that I had been very stupid.

8. He said, "How terrible the night is!"

Ans. He exclaimed that the night was very terrible.

9. "Alas! I am ruined," said the farmer.

Ans. The farmer exclaimed with sorrow that he was ruined.

10. The players said, "Hurrah ! We have won the match."

Ans. The players exclaimed with joy that they had won the match.

11

Finite and Non-finit Verbs

A. Rewrite the following sentences using infinitives. You may make necessary changes :

1. She jumped off when I tried catching her.

Ans. She jumped off to avoid catching her.

2. He has two kids whom he must look after.

Ans. He has two kids to look after.

3. Dad went back home as he wanted relaxation.

Ans. Dad went back home to relax.

4. Give me something that I can eat.

Ans. Give me something to eat.

5. Badal arrived early so that he could catch the bus.

Ans. Badal arrived early to catch the bus.

6. He started reading the lesson when the teacher arrived.

Ans. He started reading the lesson on the teacher's arrival.

7. Remember that the books should be kept on the top shelf.

Ans. Remember to keep the books on the top shelf.

8. Vivek began enjoying the work he is given.

Ans. Vivek began to enjoy the work he is given.

B. Join the following pairs of sentences using infinitives :

1. Did you know? You had to prepare for the test.

Ans. Did you know to prepare for the test?

2. He cannot afford a car. He is very poor.

Ans. He is too poor to afford a car.

3. I heard of his loss. I was sorry for that.

Ans. I was sorry to hear of his loss.

4. He wants to help old people. This is his greatest desire.

Ans. He wants to help old people to fulfil his greatest desire.

5. She is going to America. She will live there.

Ans. She is going to America to live there.

6. Mr. Das is very ill. He cannot continue work right now.

Ans. Mr. Das is too ill to continue work right now.

7. The beggar stopped at the restaurant. He wanted some food.

Ans. The beggar stopped at the restaurant to get some food.

8. She stopped the work. She stopped so that she could attend the guests.

Ans. She stopped the work to attend the guests.

C. Encircle the participle in each sentence and state whether it is a participle adjective, present participle, past participle, or perfect participle :

1. My important documents are in this locker.

participial adjective

2. Having collected some money, the children are ready for the charity.

perfect participle

3. The long journey is hectic.

participial adjective

4. Having finished the homework, the students relaxed

perfect participle

5. I met a woman crying badly.

present participle

6. The principal transferred to this school is a good philosopher.

past participle

7. Drawing out his gun, the chain-snatcher ran away.

present participle

8. Learned men will never come to begging.

past participle

D. Fill in the blanks using the present participle form of the verbs given in the box :

1. **Making** himself comfortable, he sat down to work

2. **Speaking** softly, she discussed her problem.
3. Her mother had a **shining** diamond bracelet.
4. **Talking** to himself, the man started his work.
5. We heard a sound **screaming** in the back stage.
6. **Shouting** loudly, the students ran to the classroom.
7. **Forgetting** to lock the cupboard, the girl fell asleep.
8. **Weeping** bitterly, she told the story.

E. Fill in the blanks with the '-ing' form of the verbs given in the box :

1. **Listening** to music relaxes our mind.
2. **Putting** pressure on children is not good.
3. **Reading** improves our language.
4. His hobby is **collecting** coins.
5. **Writing** is a skill.
6. **Making** fun of others is a bad habit.
7. **Running** away from problems is not a solution
8. **Sleeping** is also good for our health.
9. **Walking** in the morning is good for health.
10. **Planning** for future is very important.

F. Point out the participles and gerunds in the following sentences. In the case of the participle, name the noun or pronoun which it qualifies. In the case of the Gerund, state whether it is a subject, object, complement, or used after preposition :

1. Singing to herself was her chief aim.

Ans. Singing → **Gerund (subject)**

2. Walking on this road is forbidden.

Ans. Walking → **Gerund (subject)**

3. Hearing the music, she ran to the door.

Ans. Hearing → **Present participle (qualifies 'she')**

4. We spent the afternoon watching movie.

Ans. watching → **Present participle (qualifies 'afternoon')**

5. She preferred dancing to learning her lessons.

Ans. dancing, learning → **Gerunds (objects)**

6. Jumping over the wall, the cat escaped.

Ans. Jumping → **Present participle (qualifies 'cat')**

7. I was surprised at James being absent.

Ans. being → **Gerund (object of preposition)**

8. The year was spent in visiting historical places.

Ans. visiting → **Gerund (object of preposition)**

9. I cannot go on earning nothing.

Ans. earning → **Gerund (object)**

10. We saw a policeman making people happy.

Ans. making → **Present participle (qualifies 'policeman')**

12

Phrases and Idioms

A. Write the meanings of the following idioms and phrases, and use each in sentence of your own :

1. Give up :
 - ↳ **Meaning:** To stop doing something / to quit
 - ↳ **Sentence:** He did not give up even after many failures.
2. Give away :
 - ↳ **Meaning:** To donate or reveal something
 - ↳ **Sentence:** She gave away her old clothes to the poor.
3. Look after :
 - ↳ **Meaning:** To take care of
 - ↳ **Sentence:** She looks after her younger brother.
4. Carry out :
 - ↳ **Meaning:** To perform or complete a task
 - ↳ **Sentence:** The students carried out the project successfully.
5. Up to the mark :
 - ↳ **Meaning:** Good enough / satisfactory
 - ↳ **Sentence:** His performance was not up to the mark.
6. After all :
 - ↳ **Meaning:** In spite of everything / finally
 - ↳ **Sentence:** He came to the party after all.
7. Far and near :
 - ↳ **Meaning:** Everywhere / all places
 - ↳ **Sentence:** People came from far and near to attend the fair.
8. Bell the cat :
 - ↳ **Meaning:** To take a risk / face a difficult task
 - ↳ **Sentence:** Nobody was ready to bell the cat against the strict teacher.
9. Hard and fast :
 - ↳ **Meaning:** Fixed / strict rules
 - ↳ **Sentence:** There are no hard and fast rules for success.
10. Keep pace with :
 - ↳ **Meaning:** To move or progress at the same rate
 - ↳ **Sentence:** We must keep pace with modern technology.

13

Conditionals

Rewrite each of the following sentences as conditional sentence (type I, II, III) :

1. The zookeeper would have punished him with a fine if he **had fed** the animals.
2. If we meet at 9:30, we **will have** plenty of time.
3. Bhumika would find the milk if she **looked** in the fridge.
4. If you spoke louder, your classmates **would understand** you.

5. If you **swim** in the pool, you'll shiver from cold.
6. The door will unlock if you **press** the green button.
7. If Varun **had asked** his teacher, he'd have answered his questions.
8. I **would call** my friend if I was/were you.
9. Christina **would arrive** safe if she drove slowly.
10. You **would have had** no trouble at school if you had done your homework.

14

Punctuation

A. Rewrite the following sentences using the appropriate punctuation marks :

1. A uncles job is easier than a dads

Ans. An uncle's job is easier than a dad's.

2. It looks as if the sun goes around the earth but of course the earth really goes round the sun

Ans. It looks as if the sun goes around the earth, but of course, the earth really goes round the sun.

3. He neither smiled spoke nor looked at me

Ans. He neither smiled, spoke, nor looked at me.

4. Long ago in a distant country there lived a beautiful princess

Ans. Long ago, in a distant country, there lived a beautiful princess.

5. It was my aunt who took me to the show yesterday not my mother.

Ans. It was my aunt who took me to the show yesterday, not my mother.

6. Rohan was invited to the party but he was ill so I went instead of him

Ans. Rohan was invited to the party, but he was ill, so I went instead of him.

7. Sorry to disturb you could I speak to you for a moment

Ans. Sorry to disturb you, could I speak to you for a moment?

8. Is it any use expecting them to be on time

Ans. Is it any use expecting them to be on time?

9. Rashmi going to sleep during the party was rather embarrassing

Ans. Rashmi, going to sleep during the party, was rather embarrassing.

10. Having lost all my money I went home

Ans. Having lost all my money, I went home.

B. Put the missing punctuation marks in the following :

Construction of Metro Station

“about one hundred engineers designed the building of the Metro Station,” said Mr. Rana.

Ans. “About one hundred engineers designed the building of the Metro Station,” said Mr. Rana.

1. Let's go to the library. Mr. Sharma is talking about the Metro Construction Site suggested Parinita.

Ans. "Let's go to the library. Mr. Sharma is talking about the Metro Construction Site," suggested Parinita.

2. Govind replied That's a wonderful idea

Ans. Govind replied, "That's a wonderful idea!"

3. Noida City Centre Metro Station is one of the most crowded Metro station explained Mr. Rana

Ans. "Noida City Centre Metro Station is one of the most crowded Metro station," explained Mr. Rana.

4. Exactly how long is it asked Daksh

Ans. "Exactly how long is it?" asked Daksh.

5. The total length is 6.25 km

Ans. "The total length is 6.25 km."

6. Wow, that is long explained the girls

Ans. "Wow, that is long!" explained the girls.

7. Mr. Rana continued The station has always been painted white. The colour was selected because it blends well with the natural setting

Ans. Mr. Rana continued, "The station has always been painted white. The colour was selected because it blends well with the natural setting."

8. Why is it called the 'City Centre'

Ans. "Why is it called the 'City Centre'?"

9. Mr. Rana explained Actually the term 'City Centre' refers to as a centre of the city Here Noida is the city

Ans. Mr. Rana explained, "Actually, the term 'City Centre' refers to a centre of the city. Here, Noida is the city."

10. The labour asked How long did it take to build the bridge

Ans. The labour asked, "How long did it take to build the bridge?"

15 Letter Writing

- A. Writes a letter to his friend about his experiences on trekking. Using his notes given below, write the letter :

March 12, five friends, beauty of nature, exercise, trekking nearby
hills, Exhausted, perspired, cold wind, very happy,
easy return

House No. 45

Green Park

Delhi

March 12, 2025

Dear Rahul,

I hope you are fine. I am writing this letter to share my wonderful experience of trekking. Last week, I went on a trekking trip with five of my friends to the nearby hills.

The beauty of nature there was amazing. We saw green mountains, fresh air and enjoyed the cold wind. Although we got exhausted and perspired a lot during the climb, it was a great exercise for all of us. The view from the top was breathtaking. After spending a few hours there, we returned easily and safely. This trip made me very happy and refreshed.

I wish you were there with us. We will plan another trip soon.

With best wishes,

Yours affectionately,

Amit

- B. Write a letter to your uncle advising him not to go to the quack. Give reasons why he shouldn't:**

House No. 78

Lajpat Nagar

New Delhi

15 March 2025

Dear Uncle,

I hope you are doing well. I came to know that you are planning to take treatment from a quack. I am really worried about your health.

Quacks are not qualified doctors and their medicines can be very harmful. They may give wrong treatment which can worsen your condition. Many people have suffered serious health problems because of them.

I strongly advise you to consult a qualified and experienced doctor instead. Proper medical care will ensure your quick and safe recovery.

Please take care of your health and avoid any risk.

Yours lovingly,

Rohit

- C. Write a letter to the editor of a newspaper bringing the problem of garbage burning to the notice of the concerned authorities. Don't forget to emphasise upon the ever increasing pollution-related diseases :

House No. 22

Shastri Nagar

Delhi

20 March 2025

The Editor

The Times of India

Delhi

Subject: Problem of garbage burning in our locality

Sir,

Through the columns of your esteemed newspaper, I would like to draw the attention of the concerned authorities towards the serious problem of garbage burning in our locality.

People regularly burn garbage in open areas, which causes heavy air pollution. The smoke released is very harmful and leads to diseases like asthma, breathing problems and eye irritation. Children and elderly people are the worst affected.

Despite several complaints, no strict action has been taken. I request the authorities to take immediate steps to stop this practice and create awareness among people.

I hope the authorities will take necessary action soon.

Thanking you,

Yours faithfully,

Aman

16 Essay Writing

Write the essays on the following topics :

1. The Taj Mahal

The Taj Mahal is one of the most famous monuments in the world. It is located in Agra, on the banks of the Yamuna River. It was built by the Mughal Emperor Shah Jahan in memory of his beloved wife Mumtaz Mahal. The construction of the Taj Mahal began in 1632 and took many years to complete.

The Taj Mahal is made of white marble and is known for its beautiful design and architecture. It looks different at different times of the day. In the morning, it appears soft and pinkish, while in the evening it shines like gold. At night, under the moonlight, it looks magical and breathtaking.

The monument is surrounded by beautiful gardens, fountains, and pathways. There is also a large dome and four tall minarets which make it even more attractive. Many skilled craftsmen and workers worked hard to build this masterpiece.

The Taj Mahal is a symbol of true love and dedication. It attracts millions of tourists from all over the world every year. It is also included in the list of the Seven Wonders of the World.

The government takes special care to preserve the Taj Mahal. Visitors are also expected to maintain cleanliness and protect this heritage site.

In conclusion, the Taj Mahal is not only a historical monument but also a symbol of India's rich culture and history. We should be proud of it and do our best to protect it for future generations.

2. Union is Strength

The proverb "Union is Strength" teaches us the importance of unity. It means that when people work together, they become stronger and can achieve great things.

When we try to do something alone, we may face many difficulties. But when we work as a team, we can share our ideas and support each other. This makes the task easier and increases the chances of success.

There is a famous story of an old man and his sons. The old man gave his sons a bundle of sticks and asked them to break it. They could not break the bundle. Then he gave them one stick each, and they broke it easily. This story clearly shows that unity makes us strong.

In schools, students often work in groups for projects. When they cooperate with each other, they complete their work better and faster. In society, unity helps people live in peace and harmony. Even countries become powerful when their citizens are united.

On the other hand, disunity leads to weakness and failure. When people fight among themselves, they cannot progress.

Therefore, we should always stay united and help each other. Unity brings strength, success, and happiness in life. It is an important value that everyone should follow.

3. Advertisement

Advertisements play an important role in modern life. They help people to know about new products, services, and offers available in the market. We see advertisements everywhere, such as on television, newspapers, radio, social media, and hoardings.

Advertisements are useful because they provide information about different products. They help customers compare prices and choose the best option. For companies, advertisements are a way to promote their products and increase sales. Without advertisements, people would not know about many useful things.

However, advertisements also have some disadvantages. Sometimes they are misleading and show false information. They exaggerate the quality of products to attract customers. This can make people buy things they do not really need. Children are especially influenced by advertisements and often demand unnecessary items.

Advertisements also encourage a habit of spending money. People are tempted to buy more and more things, which leads to waste of money. In some cases, advertisements promote unhealthy products like junk food, which can harm our health.

Therefore, while advertisements are helpful, we should be careful. We should think wisely before buying anything and not believe everything shown in advertisements.

In conclusion, advertisements are an important part of our lives, but we must use our judgment and make smart decisions.

4. Child Labour

Child labour is one of the most serious problems in society. It refers to the practice where children are made to work at a very young age instead of going to school. Many children are forced to work in factories, shops, hotels, and even homes.

The main reason for child labour is poverty. Poor families cannot afford basic needs, so they send their children to work and earn money. Lack of education and awareness is another reason. Some parents do not understand the importance of education for their children's future.

Child labour is harmful in many ways. It affects the physical and mental growth of children. They miss the opportunity to go to school and learn. As a result, they remain uneducated and continue to live in poverty.

The government has made strict laws to stop child labour. Many organizations are also working to help these children by providing education and support. However, the problem still exists in many areas.

We all should take responsibility to stop child labour. We should not encourage it by hiring children for work. Instead, we should support their education and help them build a better future.

In conclusion, every child deserves a happy childhood and proper education. Child labour must be completely stopped for the progress of society.

5. The Evil of Dowry

Dowry is a social evil that has been present in society for a long time. It is a system in which the bride's family gives money, gifts, or property to the groom's family at the time of marriage.

This practice creates a heavy burden on the bride's family, especially if they are poor. Many families take loans or sell their property to meet dowry demands. In some cases, if the demands are not fulfilled, the bride is treated badly or even harmed.

Dowry leads to many serious problems like harassment, domestic violence, and even death. It also creates inequality between men and women. Girls are often seen as a burden because of dowry, which is a very wrong thinking.

The government has made laws to ban dowry, but the practice still continues in many parts of the country. People need to change their mindset and understand that marriage should be based on love and respect, not money.

Education plays an important role in removing this evil. When people become aware, they can take a stand against dowry. Young people should refuse to accept dowry.

In conclusion, dowry is a harmful practice that must be stopped. Only then can we build a fair and equal.

6. The Scene at a Hospital

A hospital is a place where people go for treatment and care. It is always full of activity and different kinds of people. Some patients come with serious problems, while others come for regular check-ups.

As we enter a hospital, we see doctors, nurses, and other staff members working busily. The reception area is usually crowded with patients waiting for their turn. Some people look worried and anxious, while others feel hopeful.

In the emergency ward, the situation is more serious. Doctors and nurses work quickly to save lives. Ambulances arrive with injured patients, and medical staff attend to them immediately. It is a place where time is very important.

The hospital environment is usually clean and quiet. There are different departments for different diseases. Patients are given proper treatment and care. Nurses play an important role in looking after patients.

Hospitals are very important for society. They help people recover from illness and lead a healthy life. Doctors and nurses work day and night to serve humanity.

In conclusion, a hospital is a place of hope and healing. We should respect the hard work of medical staff and follow their advice for good health.

7. The Scene at the Metro Railway Station

A metro railway station is one of the busiest places in a city. It is always crowded with people who are in a hurry to reach their destinations. The station is well-organized and clean.

As we enter the station, we see people standing in queues to buy tickets or recharge their cards. Security checks are conducted at the entrance to ensure safety. There are announcements about train timings and platforms.

Passengers wait patiently on the platforms. When the train arrives, people get in and out quickly but in an orderly manner. Some people are reading newspapers, while others are using their mobile phones.

The metro system is fast and convenient. It saves time and reduces traffic on roads. It is also an eco-friendly mode of transport.

There are clear signs and directions inside the station to guide passengers. Escalators and lifts are available for convenience. The staff members are helpful and assist passengers when needed.

In conclusion, the metro railway station is a symbol of modern transport. It makes travel easy, safe, and comfortable for people.

8. How to Maintain Friendship

Friendship is one of the most valuable relationships in life. A true friend is someone who understands us and supports us in all situations. Maintaining friendship requires effort, trust, and care.

Honesty is the most important quality in friendship. We should always be truthful with our friends. Trust builds a strong bond between friends. Without trust, friendship cannot last long.

We should help our friends in difficult times and share happiness with them. Being kind and supportive makes friendship stronger. Respect is also very important. We should respect each other's feelings and opinions.

Good communication is necessary to maintain friendship. We should talk openly and clear misunderstandings. Small issues should not be allowed to spoil the relationship. Forgiveness is also important in friendship.

Spending time together and sharing experiences makes friendship more enjoyable. We should appreciate our friends and make them feel valued.

In conclusion, friendship is a precious gift. To maintain it, we must be honest, caring, and understanding. A true friendship lasts forever and makes life happier.

17 Diary Writing

A. You have won a quiz competition. Express your feelings in about 100 words in the form of a diary entry :

12 March 2025

Wednesday

8:00 p.m.

Dear Diary,

Today is one of the happiest days of my life. I won the first prize in the school quiz competition. I had been preparing for this competition for many days, and all my hard work finally paid off. When my name was announced as the winner, I felt extremely proud and excited. My teachers appreciated me, and my friends congratulated me warmly. My parents were also very happy when I told them about my success. This victory has boosted my confidence, and I am now motivated to achieve more in the future.

Good night!

B. You are Shakti. You are touched by the plight of children who are forced to beg. Express your feeling in about 100 words in your diary :

24 March 2025

Monday

9:00 p.m.

Dear Diary,

Today I saw some small children begging on the streets, and it made me feel very sad and disturbed. These children should be going to school, playing with friends, and enjoying their childhood, but instead, they are forced to beg for money. Their condition is very painful and unfair. I felt helpless and worried about their future. It is the responsibility of society and the government to help such children by providing them education, shelter, and basic needs. We should also show kindness and support them in every possible way. This incident has deeply touched my heart, and I hope their lives improve soon.

Shakti

A. Prepare a speech appreciating the government's efforts to improve the quality of education. Also, discuss the literacy campaigns.

Good morning to the respected Principal, teachers, and my dear friends.

The quality of education is the foundation of a strong nation. I would like to appreciate the government's consistent efforts in making education accessible to all. Through various schemes, the government has provided better infrastructure, free study materials, and mid-day meals to encourage students. These steps ensure that every child, regardless of their background, gets a fair chance to learn and grow.

Furthermore, literacy campaigns like 'Beti Bachao Beti Padhao' and 'Sarva Shiksha Abhiyan' have successfully reached the remote corners of India. These campaigns are not just about teaching how to read and write; they are about empowering citizens. It is our collective responsibility to support these initiatives so that our country can achieve 100% literacy.

B. Nowadays, there is an increase in the number of asthma patients. Most of them are children suffering from respiratory disorders. The air pollution caused by vehicles is mainly to blame for this ailment. Write a speech on the topic in about 100 words.

Respected teachers and fellow students, good morning.

Today, I want to talk about a serious health issue. We are seeing a massive increase in the number of asthma patients, and unfortunately, most of them are children. Our young generation is suffering from chronic respiratory disorders because the air we breathe is no longer pure.

The main culprit behind this is the heavy air pollution caused by vehicles. The toxic smoke from cars and bikes is making it difficult for people to survive in cities. To fix this, we must promote walking, cycling, or using public transport. We need to take immediate action to reduce emissions and plant more trees. If we don't act now, the future will be a struggle for every breath.

Thank you.

C. On the eve of Mahatma Gandhi's birth anniversary, you are asked to deliver a speech for the morning assembly of your school. Write a speech on the topic in about 100 words.

Good morning everyone.

On the eve of Mahatma Gandhi's birth anniversary, we remember a man who changed the course of history through peace. Gandhiji, known as the Father of our Nation, taught us that truth and non-violence are the most powerful weapons. He led India to freedom by staying firm on his principles of 'Satyagraha' and simplicity.

His life is a great inspiration for all of us. He believed in self-reliance and cleanliness, and he always stood up for the rights of the common man. As students, we should follow his teachings by being honest and helping others. Let us celebrate this day by promising to live our lives with the same integrity and courage that Bapu showed the world.

Jai Hind! Jai Bharat!